

A novel underground heating system for deicing applications

Abubakar Gambo¹, Gokhan Ozgur², Ercan Sevkat¹

1 Department of Mechanical Engineering, Meliksah University, Kayseri, Turkey

2 Department of Electrical and Electronics Engineering, Meliksah University, Kayseri, Turkey

ABSTRACT

Due to the snow and ice on the roads in winter season, difficulties in transportation and accidents are unavoidable. Municipalities and residents put all their effort to clean up the streets and highways. Mechanical cleaning, salt and chemical applications, thermal heating are some common deicing and anti-icing methods currently used. Many of these methods have some disadvantages. While the salt and chemicals harm the concrete and steel reinforcement, thermal methods are quite expensive and difficult to install. Mechanical cleaning is labor extensive and costly. Environmental effects of using salt and chemical in long term cannot be neglected. Once all deicing techniques are reviewed, it is obvious that low-cost, efficient deicing technologies needed to be developed. In this study, for deicing and anti-icing purposes concrete was heated using carbon fiber electrical resistance technique. Heating panels were placed into the concrete and their heating performance was tested in different ambient temperatures. The effect of heat panel depth, carbon fiber form, power density and ambient temperature on the heating performance was studied. Once experimental study was completed, field application of the heating system was constructed and tested. It was concluded that carbon fiber heating system offers a viable solution for icing and snow accumulation problems.

INTRODUCTION

Cold regions experience heavy snow fall and ice accumulation on streets, pavements, bridges, and air runways during winter. In order to avoid accidents, ice and snow need to be cleaned up immediately. Conventionally, removing ice and snow from surface can be achieved by several methods such as mechanical, chemical, and thermal. While mechanical cleaning is labor intensive and costly, chemical methods cause some hazards to concrete and environment. Underground thermal heat methods are also used in some critical applications but their drawback is construction and maintenance difficulties as well as high cost.

As an innovative technique conductive concrete has been manufactured and electrical heating was achieved by Tuan et al [1]. Concrete became electrically conductive by adding some metallic fibers and conductive particles. Successful deicing and snow melting was reported. However obtaining enough electrical conductivity, the amount of conductive particles should be more than certain amounts. Increasing volume fraction of these additives may result in decrease at the mechanical properties and impairment at the surface of concrete. Zuquan Tang et al. [2] carried out an experiment to investigate the effect of thermal conductivity of

carbon fiber reinforced concrete (CRFC), temperature and thickness of ice, power output on deicing performance, and energy consumption. They finally concluded that, the time to melt the ice decrease with the increasing power output and ice temperature, and increase with the increasing thickness of the ice. Ting Yang et al. [3] used a plain woven carbon fiber tape to create heating panels for deicing experiments. Electrically conductive epoxy was used to connect the carbon fiber tape and the electrode. Four heating panels were arranged and the total electrical resistance of the electrode and the heating panels was between 0.9 and 1.1 Ω . The heating panels were then embedded into pavement with 10 cm thickness. During the experiment, 24 V ac was supplied to the heating panels for heat generation. During the winter season of 2010 three anti-icing tests and sixteen deicing tests were carried out on the sidewalk. The system worked consistently and the time required to melt the snow on the sidewalk was 7.5 hrs. Kun Zhang et al. [4] fabricated conductive concrete slabs with two types of nickel particles with different particle size in the range of 3 - 7 μm and 2.6 - 3.3 μm respectively. The performance of electrical resistance heating, the conductive properties, and the effect of voltage input on the electrical heating resistance of the cementitious composite were investigated. The deicing experiment and the snow melting experiment were conducted in refrigerator and open-air environment respectively. The experimental results indicated that as the content level of the nickel particles intensified, the electrical resistance of the cementitious composite drop abruptly.

EXPERIMENTAL STUDY

Carbon fiber is semi-conductive and known with superior mechanical properties. It is used for reinforcing polymer and ceramic matrix composites. It is especially used in aerospace application due to its low density. It is manufactured in the form of filament and then weaved as fabric (Fig.1). Since it has conductivity, applied current cause some heat generation. This property can be utilized in deicing applications. Once considered as resistance it can be connected as resistances in parallel and series arrangement. Resultant resistance of circuit consist of carbon fibers determine the heat capacity of system (Fig.2).

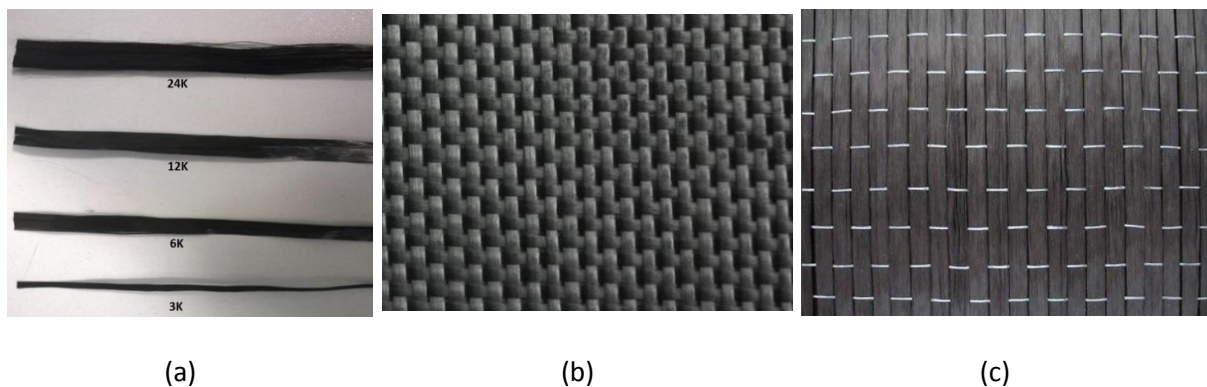

Figure 1. Forms of carbon fiber (a) Filament, (b) Woven fabrics, and (c) unidirectional fabric.

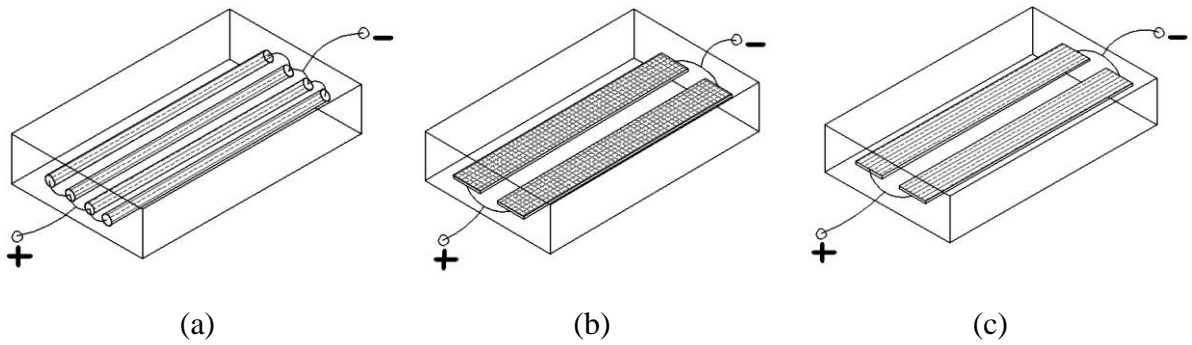
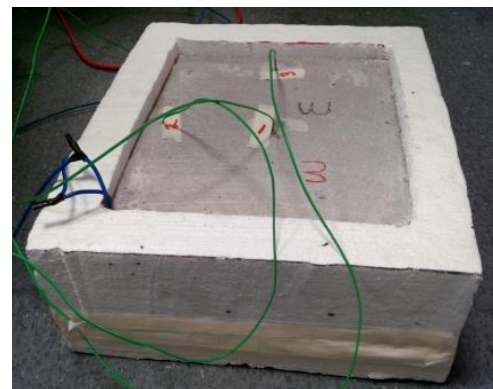
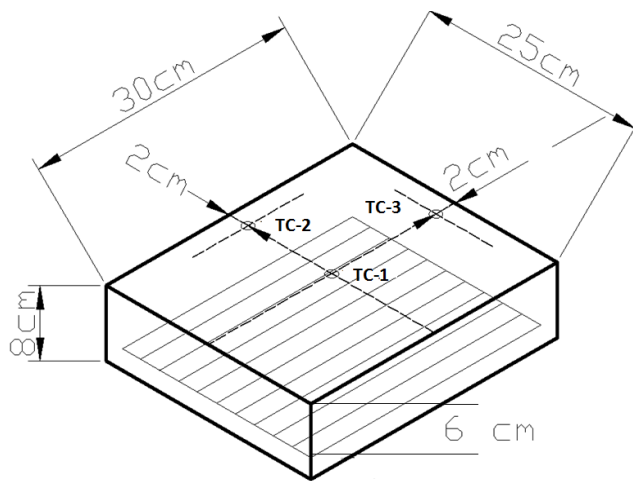

Figure 2. (a) Carbon filament heat panel, (b) Woven carbon fabric heat panel and (c) Unidirectional carbon fabric heat panel embedded concrete blocks.

These circuits then embedded into concrete and used for heating the surface of concrete (Fig.3). Concrete blocks with heating panels were manufactured and tested. Temperature changes of blocks were captured using thermocouples attached at the top surface. Heat performance tests conducted at various ambient temperatures are shown in Figure 3. Reaching the surface temperature of 0 °C took 30, 66 and 207 minutes for the tests conducted at ambient temperatures of -5 °C, - 10 °C, -20 °C. Surface temperature did not reach 0 °C when ambient temperature was -30 °C.



(a) **(b)**

Figure 3 (a) Concrete block with three thermocouples, (b) Concrete block in Styrofoam insulation

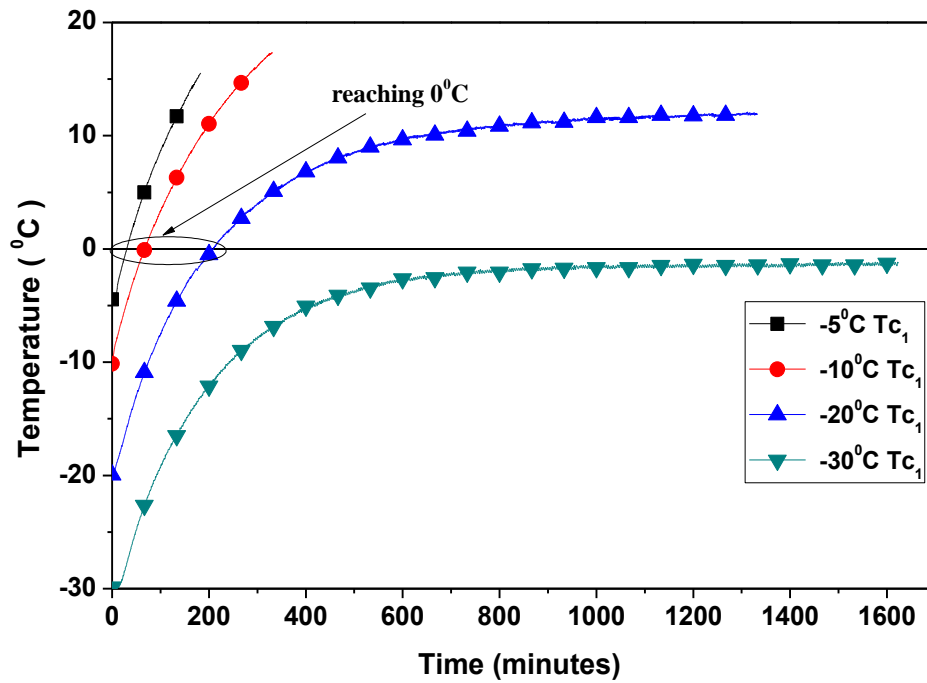

Figure. 4 Surface temperature changes of carbon filament heat panel embedded concrete block tested at ambient temperature of -5, -10, -20, and -30 °C

Following the completion of laboratory test, field application of the underground heating system was established in campus. System was constructed at the entrance of Research and Development Center. The location was approximately 60 m² and contained handicapped slope, stairs and pavement (Fig.5).



(a) Insulation at the bottom

(b) Heat panels

(c) Thin layer of concrete application

(d) Pavement

Figure 5 Construction of heating system.

Heating system was tested during the winter season of 2015-2016 and system was capable of melting snow and ice. Six heat experiments conducted at various ambient temperatures. It was observed that carbon fiber heating system can offer viable solution for deicing and snow melting problems. Figure 6 shows result of heat experiment conducted on December 30 2015.



(a) Beginning

(b) 1 hour later



(c) 2 hours later

(d) 3 hours later

Figure 6 Heating experiment conducted on December 30 2015

CONCLUSION

Carbon fiber electrical resistance heating system was constructed and tested both on small scale concrete specimens and field application. A novel heating system is easy to manufacture and cost-effective deicing and snow melting procedure. Compared to other underground heating systems, it offers many advantages. Heating system successfully melted snow with 10 cm thick snow in approximately 3 hours.

ACKNOWLEDGEMENTS

The research was conducted thanks to Ministry of Industry and Trade of TURKEY through the research grant No. 0272.STZ.2013-2. The authors would like to express their thanks for funding.

REFERENCES

- [1] Tuan, C.Y., 2008. Roca Spur Bridge: the implementation of an innovative deicing technology. *Journal of Cold Regions Engineering*, 2008.22 (1):1–15.
- [2] TANG Zu-quan, LI Zhuo-qiu and XU Dong Liang. Influence of carbon fiber contents on the temperature sensibility of CFRC Road Material. *Journal of Wuhan University of Technology-Mater.Sci.Ed.* 2002.17(3):75-78
- [3] Ting Yang, Zhaohui Joey Yang, Mithun Singla, Gangbing Song; and Qiang Li. Experimental Study on Carbon Fiber Tape–Based Deicing Technology. *Journal of Cold Regions Engineering*, 2012.26:55-70
- [4] Kun Zhang, Baoguo Han, Xun Yu, Nickel particle based electrical resistance heating cementitious composites. *Cold Regions Science and Technology*, 2011.69(1): 64-69