

HEALTH PATIENT MONITORING SYSTEM

A THESIS SUBMITTED TO  
THE FACULTY OF ARCHITECTURE AND ENGINEERING  
OF  
EPOKA UNIVERSITY

BY

FRENK TOPÇIU

IN PARTIAL FULFILLMENT OF THE REQUIREMENTS  
FOR  
THE DEGREE OF MASTER OF SCIENCE  
IN  
ELECTRONICS AND COMMUNICATION ENGINEERING

JULY 2022

## Approval sheet of the Thesis

This is to certify that we have read this thesis entitled “**Health Patient Monitoring System**” and that in our opinion it is fully adequate, in scope and quality, as a thesis for the degree of Master of Science.

---

Dr. Arban Uka  
Head of Department  
Date: July,15,2022

Examining Committee Members:

Assoc. Prof. Dr. Carlo Ciulla (Computer Engineering) \_\_\_\_\_

Dr. Shkëlqim Hajrulla (Computer Engineering) \_\_\_\_\_

Dr. Valmir Bame (Computer Engineering) \_\_\_\_\_

**I hereby declare that all information in this document has been obtained and presented in accordance with academic rules and ethical conduct. I also declare that, as required by these rules and conduct, I have fully cited and referenced all material and results that are not original to this work.**

Name Surname: Frenk Topçiu

Signature: \_\_\_\_\_

# ABSTRACT

## HEALTH PATIENT MONITORING SYSTEM

Topciu,Frenk

M.Sc., Department of Computer Engineering

Supervisor: Assoc.Prof.Dr. Carlo Ciulla

Taking care of our family member health it becomes a very difficult task nowadays. We all have or at least know, an elderly family member that we are always worried about their health. In this thesis I will try to explain and demonstrate a system that can monitor health of the patient. This system will demonstrate and it will monitor the health of the patient as a routine check,for example monitoring health of an elderly patient.This system uses pulse sensor and temperature to monitor and inform about our family members health.

There are five sensors in this monitoring system:

- 1)Temperature sensor -which measures the body temperature of the patient.
- 2)Pulse sensor-which measures the pulse of the patient.
- 3)Humidity sensor-which check the humidity in the air.

The sensors are connected to a controller and this controller is connected to the internet using GSM module to report alerts or update the stats of the patient. If the system detects any changes in pulse or the body temperature,it will alert the person that is monitoring the patient over the IoT and details and useful information about the patient in real time.

The controller, in this case ARDUINO MEGA 2560 is an open-source electronics platform based on easy-to-use hardware and software is used to analyze the different inputs that comes from pulse sensor so it can send an alert to the monitoring system. Another very useful thing is that all the processes and all the inputs for the different sensors on the system are recorded online. We all know that privacy and confidentiality of the information is important. In my opinion, this monitoring system that I'm building is a prototype. Of course as a prototype, it will need a lot of work to be a perfect monitoring system and one of the part will be the security of the privacy. These records can be used later or in the future for fully analysis and review of the patient's health condition.

By fully analysis I mean that the patient will be monitored lets say 30 days. After the monitored period, a doctor will analyze and give feedback regarding the health of the patient. IoT patient health monitoring system will effectively use the internet to track all the patient health records and stats.

**Keywords:** pulse sensor, temperature sensor, GSM module, Arduino, IoT (Internet of Things), health.

# ABSTRAKT

## SISTEM MONITORIMI I SHËNDETIT TË PACIENTËVE

Topçiu, Frenk

Master Shkencor, Departamenti i Inxhinierisë Kompjuterike

Udhëheqësi: Assoc. Prof. Dr. Carlo Ciulla

Të kujdesemi për shëndetin e familiarëve tanë është një detyrë shumë e vështirë në ditet e sotme. Të gjithë ne kemi ose të paktën njohim një pjestarë të moshuar në familjen tonë që jemi gjithmonë të shqetësuar për shëndetin e tyre. Në këtë tezë do të përpiqem të shpjegoj dhe të realizoj një sistem që mund të monitorojë shëndetin dhe ecurin e një pacienti. Ky sistem do të demonstrojë dhe do të monitorojë shëndetin e pacientit si një kontroll rutine. Në këtë sistem do të përdoret sensor i pulsit, sensor i lagështisë dhe një sensor temperature të cilët do të bëjnë të mundur monitorimin e shëndetit të pacientit.

Sensorët të cilët do të përdoren në këtë sistem janë si më poshtë:

- 1) Sensori i temperaturës- do të masi temperaturën e trupit të pacientit.
- 2) Sensori i pulsit -do të masi pulsin e pacientit.
- 3) Sensori i lagështisë- do të masi lagështinë në ambientin ku po qëndron pacienti.

Sensorët do të jenë të lidhur me një kontrollër, në rastin tim një Arduino dhe ky kontrollër do të jetë i lidhur në internet me anë të modulit të GSM në mënyrë që të bëjë të mundur ngarkimin e informacioneve dhe matjeve që do të kryhen nga sensorët e lartpërmëndur.

Kontrollëri ARDUINO MEGA 2560 është një burim i hapur për platformën e elektronikës dhe bazohet në një principël mjaft të lehtë për te punuar. Arduino do të bejë të mundur të marrë informacionet nga sensorët si, sensori pulsit, sensori lagështise dhe sensori temperaturës dhe do të shfaqe të dhënat në Web. Nje diçka pozitive për këtë sistem është që të gjitha proceset apo matjet nga të gjithë keto sensoret do të regjistrohen online. Ne të gjithë e dimë që privatësia dhe konfidencialiteti për njerëzit është diçka shumë e rëndesishme. Në opinionin tim, ky sistem monitorimi që unë po ndërtoj është një prototip. Normalisht si një prototip ka anët pozitive dhe negative dhe do të duhet shumë punë që të jetë perfekt.

Një pjesë e cila kërkon shumë zhvillim është pikerisht ruajtja dhe privatësia e të dhënave të pacientit. Këto matje dhe informacione do të përdoren për të analizuar dhe kontrolluar më mirë shëndetin e pacientit nga persona të kualifikuar sic janë mjekët apo infermierët. Ky sistem do të bazohet në IoT dhe do të përdorë në mënyrë sa më efikase dhe sa më të sigurit internetin.

***Fjalët kyçe:*** sensor pulsi, sensor temperature, moduli GSM, Arduino, IoT, shëndeti.

*Dedicated*

*TO MY FAMILY*



## ACKNOWLEDGEMENTS

*“If the only prayer you ever say in your entire life is  
thank you, it will be enough.”*

### **Meister Eckhard**

This paper is the finalization of a long cycle, a cycle which would be very difficult without the support of some special people, to whom I would like to cordially dedicate this thanks as well as my gratitude.

Many thanks go to the leading lecturer of the topic Assoc. Prof. Dr. Carlo Ciulla, for all the help he has given me in the function of this paper.

Thanks go to some of my friends and some special people for me who have supported me, encouraged me to move forward and most importantly, who have been always by my side.

Sincere thanks also go to all the professors, especially those of the department of computer engineering, who have been tireless and always ready to come to our aid and helped me also guided me perfectly to achieve something in my life.

And finally, what I am never thankful for is my Family, which has made the greatest contribution to my formation and progress.

# TABLE OF CONTENTS

|  |      |
|--|------|
| ABSTRACT .....   | iii  |
| ABSTRAKT .....   | v    |
| ACKNOWLEDGEMENTS .....   | viii |
| TABLE OF CONTENTS .....  | 1    |
| LIST OF TABLES .....   | 5    |
| LIST OF FIGURES .....  | 6    |
| CHAPTER 1 .....  | 8    |
| INTRODUCTION .....   | 8    |
| 1.1 Introduction .....   | 9    |
| 1.2 Introduction to IOT .....  | 11   |
| CHAPTER 2 .....  | 13   |
| LITERATURE REVIEW .....  | 13   |
| 2.1 Remote Patient Monitoring System .....   | 13   |
| 2.2 A framework for the comparison of mobile patient monitoring systems .....                  | 13   |
| 2.3 IoT-Based Health Monitoring System for Active and Assisted Living .....                    | 14   |
| 2.4 Real time patient monitoring system based on IoT .....                                     | 14   |
| 2.5 IoT-Based Patient Monitoring System using ECG Sensor .....                                 | 15   |
| 2.6 Internet of Things: Remote Patient Monitoring Using Web Services and Cloud Computing ..... | 16   |
| 2.7 Intelligent wireless mobile patient monitoring system .....                                | 16   |
| 2.8 A Review of Embedded Systems Education in the Arduino Age .....                            | 17   |

|  |    |
|--|----|
| 2.9. Study of arduino microcontroller board .....  | 17 |
| 2.10 A survey on ECG analysis .....  | 18 |
| 2.11 Cardiovascular effects of social support in the workplace: twenty-four-hour ECG monitoring of men and women. ....   | 18 |
| 2.12 Deep Learning for ECG Classification.....   | 19 |
| 2.13 Internet of things: A survey .....  | 19 |
| 2.14 Research On the architecture of Internet of Things .....  | 20 |
| 2.15 The Internet of Things – promise for the future?.....   | 20 |
| 2.16 The internet of Things: An Overview Understaing The Issues and Challenges of a More Connected World .....   | 21 |
| 2.17 Internet of Things (IoT) for Next-Generation Smart Systems: A Review of Current Challenges, Future Trends and Prospects for Emerging 5G-IoT Scenarios ..... | 22 |
| 2.18 IoT security: Review, blockchain solutions, and open challenges, Future Generation Computer Systems .....   | 22 |
| 2.19 IoT Middleware: A Survey on Issues and Enabling Technologies .....  | 23 |
| 2.20 IoT Network Security: Threats, Risks, and a Data-Driven Defense Framework .....   | 24 |
| 2.21 Internet of things (IoT) security: Status, challenges and prospective measures .....  | 24 |
| 2.22 IoT and cloud convergence: Opportunities and challenges .....   | 25 |
| 2.23 IoT Healthcare: Benefits, Issues and Challenges .....   | 25 |

|  |    |
|--|----|
| 2.24 Healthcare IoT.....   | 26 |
| 2.25 An implementation of IoT for healthcare .....   | 26 |
| 2.26 Design and implementation of interoperable IoT healthcare system based on international standards ..... | 27 |
| 2.27 IoT for Healthcare .....  | 28 |
| 2.28 A Wearable, Low-Power, Real-Time ECG Monitor for Smart T-shirt and IoT Healthcare Applications .....    | 28 |
| 2.29 An Investigation on IoT Healthcare Analytics .....  | 29 |
| 2.31 The working principle of an Arduino .....   | 30 |
| 2.32 Arduino as a learning tool.....   | 30 |
| 2.33 Influence of Arduino on the Development of Advanced Microcontrollers Courses .....                      | 31 |
| 2.34 Study of Arduino microcontroller board .....  | 31 |
| 2.35 Open-Source Hardware Is a Low-Cost Alternative for Scientific Instrumentation and Research .....        | 32 |
| 2.36 Research on IoT Privacy Security Risks .....  | 32 |
| 2.37 Data Security and Privacy in the IoT .....  | 33 |
| 2.38 A view on privacy & trust in IoT .....  | 33 |
| 2.39 A Medical Healthcare System for Privacy Protection Based on IoT .....                                   | 33 |
| 2.40 Fundamentals for IoT networks: secure and low-latency communications ...                                | 34 |
| CHAPTER 3.....   | 35 |

|                                  |    |
|----------------------------------|----|
| 3.1 Feasibility .....            | 36 |
| 3.2 Ethical Issues .....         | 37 |
| CHAPTER 4 .....                  | 38 |
| METHODOLOGY .....                | 38 |
| CHAPTER 5 .....                  | 39 |
| TOOLS NEEDED .....               | 39 |
| 5.1 Arduino Mega 2560 .....      | 39 |
| 5.2 GSM Module .....             | 43 |
| 5.3 HeartBeat Sensor.....        | 46 |
| 5.4 Temperature sensor LM35..... | 48 |
| CHAPTER 6.....                   | 50 |
| IMPLEMENTATION IN PRACTICE ..... | 50 |
| RESULTS AND DISCUSSION.....      | 64 |
| CONCLUSION .....                 | 67 |

## LIST OF TABLES

|   |   |
|---|---|
| Table 1: Prices for all the parts needed..... | 9 |
|---|---|

## LIST OF FIGURES

|   |                                     |
|---|-------------------------------------|
| Figure 1: Patient's health monitoring systems .....                                   | 11                                  |
| Figure 2: IoT.“That’s why the Internet of Things needs artificial intelligence” ..... | 11                                  |
| Figure 3: Top view of Arduino Controller .....  | 40                                  |
| Figure 4: Side view of Arduino Controller 1 .....                                     | <b>Error! Bookmark not defined.</b> |
| Figure 5: Side view of Arduino Controller 2 .....                                     | <b>Error! Bookmark not defined.</b> |
| Figure 6: Side view of Arduino Controller 3 .....                                     | 41                                  |
| Figure 7: Side view of Arduino Controller 4 .....                                     | 42                                  |
| Figure 8:Top view of GSM Module SIM800.....   | 44                                  |
| Figure 9 : Bottom side of GSMi Module SIM800.....                                     | 44                                  |
| Figure10:Pinout diagram of GSM module SIM800. ....                                    | 45                                  |
| Figure 11: Heart Beat Sensor .....  | 46                                  |
| Figure 12: Pinout diagram of pulse sensor.....  | 47                                  |
| Figure 13:Pulse detection method through light called Photoplethysmogram.....         | 47                                  |
| Figure 14: LM35 Pinout.....   | 48                                  |
| Figure 15: LM35.....  | 48                                  |
| Figure 16: DS18B20 circuit diagram using LM35 and resistor .....                      | 49                                  |
| Figure 17.Circuit Diagram .....   | 62                                  |
| Figure 18.Heart Rate on Thingspeak .....  | 63                                  |

|  |    |
|--|----|
| Figure 19. Temperature on Thingspeak ..... | 63 |
| Figure 20. Humidity on Thingspeak .....    | 63 |



# CHAPTER 1

## INTRODUCTION

### **Motivation**

For a long time, we have been fascinated by the advancements in technological growth. Aside from this, we discovered that there are no serious examinations of computerization technology for hospital Internet of Things-based Patient Monitoring Systems. In addition to them, I began searching for previously published papers and technological breakthroughs in our immediate vicinity. Currently, medical research is progressing and becoming more advanced daily. Considering this developing approach, individuals are progressing more important logical frill, for example, dazzling belts that detect continuous breath and also electro dermal movement (EDA) sensors that sequentially display for physiological symptoms of seizures throughout the nighttime. The patient monitoring system is significantly more easily accessible, pleasant, and seamless for the patient than other systems.

Recently developed novel technologies that are implanted in the patient's body to allow them to resume their normal activities. For doctors and nurses, it might be difficult to determine the health status of a patient at certain points in time. As a result, they are unable to provide the patient with the appropriate treatment and immediate results. At this point, it is critical to put in place a system that will assist doctors and nurses in keeping track of their patients.

In this project the limitations are that this system only uses pulse sensor,ecg sensor,temperature sensor and humidity sensor.In the feature we can use different sensors for example:diabetes sensor,motion sensor,ear sensor,EEG and Oxygen saturation (SpO2). The biggest problem of the health monitoring system is security of private information of the patient.At this moment in my opinion there is no solution for information security because of different methods of hacking IoT devices.

| <b>Parts</b>          | <b>Price</b>    |
|-----------------------|-----------------|
| Arduino Mega 2560     | 35.49\$         |
| Pulse Sensor          | 24.99\$         |
| GSM Module SIM800     | 12.99\$         |
| Humidity Sensor DHT11 | 9.99\$          |
| LCD Display           | 12\$            |
| LM35                  | 3\$             |
| Jumper wires          | 10\$            |
| <b>TOTAL COST</b>     | <b>108.46\$</b> |

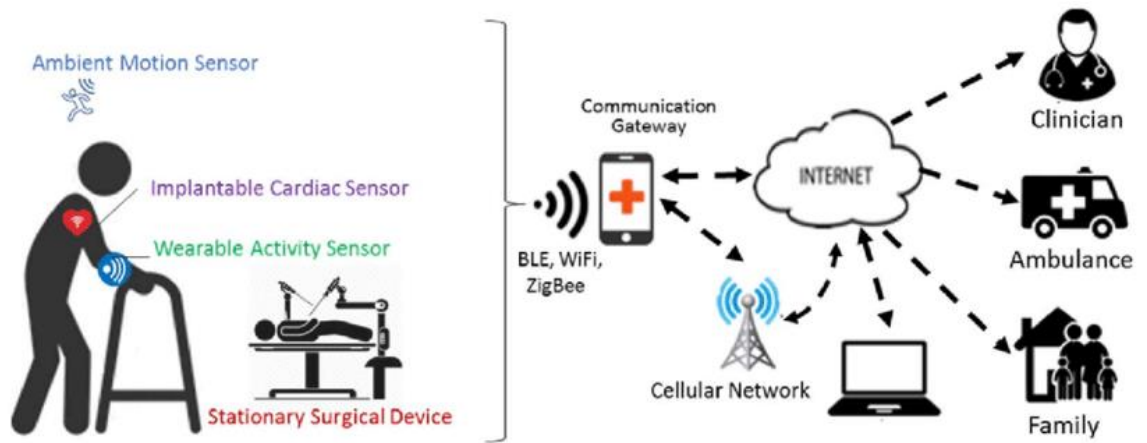
*Table 1:* Prices for all the parts needed

## **1.1 Introduction**

The condition of a patient's vital organs can be tracked remotely using a Health Patient Monitoring System, which is an extension of a hospital medical system. To determine whether a specific intended result or set of results has actually occurred following the application of any clinical process or substance, monitoring must be performed. Monitoring also serves to provide ongoing oversight to the quality of care provided to meet the needs of a person's needs. Detection systems were formerly primarily present at healthcare facilities and were distinguished by their large, complicated circuitry that needs a lot of power. Now days semiconductors have been manufactured in advanced technology and resulted in sensors and microcontrollers that have been shrunk down to a more manageable size, faster, consume less power, and are less expensive. In electronics, a semiconductor device is a component whose operation is dependent on the characteristics of the material used to make the device. Vacuum tubes are changed by the semiconductors.

According to study, roughly 2000 people die each month because of their own health irresponsibility. This is because they don't have time for themselves and, because of their hectic schedule, they neglect their health management. The motivation for creating this project is from the developing world of technology which causes people to overlook regular health checkups, which should be done monthly or quarterly. The internet of things, as we all know, makes our lives easier. As a result, we've chosen to create an internet of things-based healthcare initiative for people who submit all their personal health information on their mobile phone and can access all their historical health data.

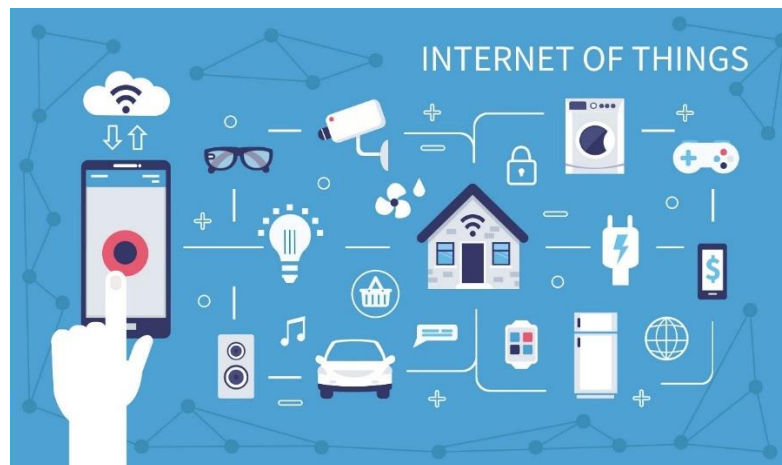
The nicest feature about this initiative is that it is accessible to everyone and simplifies our health management compared to existing methods. It may be used to measure body factors such as ECG, temperature, moisture, and heartbeat. It also identifies the patients' physical state and location. The patient's location is needed just in case in any scenario his/her health may not be good, the patient is not capable to call an ambulance or an emergency number so the doctor or let's say the monitoring system will alert the person that is monitoring the patient health. By alert I mean that it will show the current location using a GSM module. This system also sends out alerts to the person that is in charge of monitoring the health of the patient and it will send alerts to a family member when they are needed, such as when there are any critical circumstances or messages about drugs, location changes, or other conditions.



**Figure 1:** Patient's health monitoring systems

## 1.2 Introduction to IOT

In the Internet of Things, all devices that have sensors and the ability to collect data through a network without the need of an operator is called a “thing”. The technology used in these objects allows it to interact with both the external world and also the internal states. This interaction aids in decision-making.



**Figure 2:** IoT. “That’s why the Internet of Things needs artificial intelligence”

In a word, the Internet of Things (IoT) is a concept that connects all your devices to the network and makes the communication possible with many devices. The Internet of Things (IoT) is a large network of devices that collect,interacte and share information about how they are utilized and the settings in which they operate. Each of your gadgets will learn from the experiences of other devices in the same way that humans do. IoT aims to increase human interdependence by allowing people to interact with, contribute to, and collaborate with objects.

## CHAPTER 2

### LITERATURE REVIEW

#### **2.1 Remote Patient Monitoring System**

Health monitoring systems are becoming more prevalent in the delivery of routine health care and healthcare administration. Many patients in underserved areas are obtaining services that they would not have obtained otherwise unless they traveled a long distance or overcame other transportation obstacles [1]. Telemedicine is the transfer of medical information from one location to another through the use of electronic communication, with the goal of improving the health state of patients. Telemedicine could be used for a variety of services, including wireless tools, email, two-way videoconferencing, cellphones, and other types of telecommunications technology. Telemedicine services cover everything from primary care to highly specialized treatments offered by major academic healthcare institutions.. Services are provided to patients of all ages, from the very young to the very elderly. Hospitals, clinics, nursing homes, rehabilitation hospitals, residential assisted living institutions, schools, jails, and health agencies all use telehealth systems [2].

#### **2.2 A framework for the comparison of mobile patient monitoring systems**

Electronic health (e-Health) is a long-standing phrase that refers to the use of information communication and technology in the healthcare industry [3]. With the advent of mobile communications and powerful networking technology, a new discipline within e-Health has emerged: Mobile Health (m-Health) [4]. One of the m-Health services is mobile patient monitoring, which is used to measure and analyze a mobile patient's bio signals on a continuous or periodic basis. The positive thing of

persistent monitoring is that we have records of health changes of the patient and in this way the doctors can see the records of the past days. Bio signals are the physiological signals that can be detected and monitored (continuously or occasionally) from living creatures [4]. Electroencephalogram (EEG), Magnetoencephalogram (MEG), Galvanic Skin Response (GSR), and Electrocardiogram (ECG) are only a few of the bio signals that are commonly monitored [4]. Many more metrics may be estimated (derived) from observed bio signals, including Heart Rate Variability (HRV) [5].

### **2.3 IoT-Based Health Monitoring System for Active and Assisted Living**

IoT platform is a feature technology for providing the health monitoring services [6] and it has the potential to improve medical service further. Simply the Internet of Things consists of any device with an on/off switch that involves machines communicating information over the internet and has not been around for very long. The concept of the Internet of Things was not officially named until 1999. The first example of IoT is from 1980s, and was a Coca Cola machine which was located at the “Carnegie Mellon University.” Kevin Ashton, “MIT Executive Director of Auto-ID Labs”, named the phrase “Internet of Things” in 1999. IoT platforms may be used to gather the necessary information from the user and the surrounding environment and transmit it wirelessly, where they can be processed or stored to build the user's history [6]. It will be possible to take preventative actions or provide emergency treatment with such interconnection to other devices and services.

Several IoT solutions for IoT healthcare and assisted living applications have recently been created [6].

### **2.4 Real time patient monitoring system based on IoT**

In the field of remote monitoring, the popularity of the Internet of Things is growing by the day. The benefits of remote monitoring health is that the patient can

do his/her daily routine and in my opinion this is the perfect moment or the perfect time to measure and monitor the health of that patient. [7].

We describe an intelligent patient monitoring system that features sensor-based connected networks to monitor patients' health autonomously in this study. The system is more advanced in that it can identify a patient's serious condition by evaluating data from the sensors and delivering push notifications to doctors, nurses, and health authorities. To be a perfect health tracking system, hospitals should have a personnel focused just to remain focused on the patients' remote monitoring system in order to make it more simple and effective. Doctors and nurses benefit from this method since it allows them to keep track of their patients without the need to see them in person. Patients' relatives can also profit from this method due to the obvious restricted access [8].

## **2.5 IoT-Based Patient Monitoring System using ECG Sensor**

Whether in a hospital setting or at the patient's own home, patient monitoring is a significant element of the modern healthcare system. As a result of this research, an intelligent patient monitoring system has been developed. The system makes use of a number of sensors in order to perform an automated check on the patient's state of health. After being processed on a Raspberry Pi, the data is subsequently stored in the cloud associated with the internet of things [9].

Obtaining the biosignal, in this case an ECG, through the use of an ECG sensor would be the primary purpose of the system. Because of constant monitoring and graphical representation of the patient's data, medical professionals such as doctors and nurses are able to check on the patient's condition from a remote location. In the event that the circumstance becomes life-threatening, an alert will be sent to the staff or relatives of the patient informing them about the patient condition [9].



## **2.6 Internet of Things: Remote Patient Monitoring Using Web Services and Cloud Computing**

The purpose of this article is to outline the steps necessary to develop a mobile application for the medical field that is powered by Android and that makes use of the Internet of Things and cloud computing principles. They came up with the idea for the "ECG Android App," which provides the user with a graphical depiction of the waves produced by their electrocardiogram [10], in addition to performing data recording activities in the background. The data that was logged can be moved to the user's personal centralized cloud or to a medical cloud that is devoted solely to the storage of medical records. This keeps a record of all the data that was monitored and allows medical personnel to access it for analysis. The study concentrates on system design and software development, which are both essential for the internet-of-things as well as cloud-based healthcare applications in general. The research suggests that the infrastructure that was examined can also be used to several other aspects of medical treatment. It concludes with some recommendations for the scalability of the solution within the medical industry [11].

## **2.7 Intelligent wireless mobile patient monitoring system**

These days, heart diseases seem to be on the rise. In today's stress-filled world, cardiac arrest is recognized as a main factor to the increasing occurrence of sudden and unexpected deaths. A system that automatically warns a person whenever they are starting to develop a condition will be a blessing to society [12]. This may be accomplished by integrating wireless technology into the patient monitoring system that is currently in place.

In this work, a suggestion is made for the construction of a module that would provide mobility not only to the patient but also to the attending physician. This would be achieved by adopting a technique that is not only simple but also widely used: identifying irregularities in the patient's bio signal in advance and sending an alarm SMS to the doctor via the Global System for Mobile Communications (GSM) (GSM). This would enable the doctor to take the necessary preventative measures

and

bring the patient's critical level down [12].

## **2.8 A Review of Embedded Systems Education in the Arduino Age**

The topic of embedded systems education in the Arduino era is investigated in this study. Arduino is an open-source microcontroller platform that has gained a lot of traction among enthusiasts and academics over the last decade [13]. Advantages of embedded systems are as below:

- They are cheaper to design and build because of the limited number of functions.
- They require less power and some of the embedded systems run only using batteries.
- They can be built using cheaper and less powerful processors.

Arduino is becoming more widely used in a variety of fields in schools and colleges. Therefore, multiple articles about Arduino integration in teaching are published every year in various engineering education conferences and publications [14]. The influence of Arduino on embedded systems education is studied in this paper [14]. The literature is used to identify the obstacles that embedded systems education faces. Second, several Arduino teaching integration approaches are examined and assessed in the literature. Third, the subject of whether Arduino is successful in addressing embedded education difficulties is examined, considering both survey results and contemporary market developments [14].

## **2.9. Study of the arduino microcontroller board**

The functioning concept and uses of the Arduino microcontroller will be discussed in this presentation [15]. Additionally, we will explain a description of how the Arduino microcontroller works may be utilized as a tool for research in this paper [16]. The Arduino microcontroller may be used to quickly construct tiny sensor-based applications. The Arduino microcontroller is simple to understand and program because it uses programming languages such as C and C++. The Arduino IDE allows

you to program the Arduino microcontroller. The Arduino IDE is a program-writing tool for Arduino boards. The Arduino IDE is free software that is open source and you may download and install on your computer. The Arduino IDE comes with several ready-to-access library collections. Arduino programmers will save a lot of time if they use these libraries. This paper discusses the several types of Arduino boards, the underlying operating principles, the software implementation, and the applications of Arduino [17].

## **2.10 A survey on ECG analysis**

The electrocardiogram (ECG) signal mainly shows the heart's electrical activity [18]. In the literature, the ECG signal has been analyzed and used for a variety of purposes, including heart rate monitoring, cardiac rhythm analysis, treatment of cardiovascular disease, emotion recognition, and biometric authentication [19]. Depending on the type of investigation, pretreatment, extraction of features, feature selection, feature transformation, and categorization are some of the processes in an ECG analysis [20]. To complete the necessary analysis, each stage must be completed. The success measures utilized, as well as the efficient method of the ECG signal database, are also important in the analysis [21].

The publications on ECG analysis is completely investigated in this study, primarily, departing since the last century, and it is mentioned within the context of the concept listed above.

## **2.11 Cardiovascular effects of social support in the workplace: twenty-four-hour ECG monitoring of men and women**

In epidemiological research, psychosocial job features such as work demand, work control, and social support at work have been linked to the development of coronary heart disease. The processes behind the social and psychological influences on the cardiovascular system, on the other hand, remain unknown. In 148 working men and women spanning seven distinct occupational categories, we investigated the direct cardiovascular impact of psychosocial work environment variables [22].

Aside from conventional measures of job demand, work control, and social support, electrocardiograms were monitored ambulatorily 24 hours a day, 7 days a week in the usual work and home context. Blood pressure was monitored in both systolic and diastolic forms, as well as other basic physiologic risk indicators for coronary heart disease. People who announced little social support at work had considerably increased heart rates on average. During working hours, as well as during leisure and repose, this impact was sustained. Among the other linked physiologic risk variables, systolic blood pressure was shown to be greater in people who reported low social support, but not diastolic blood pressure. Social support at work was unaffected by smoking, alcohol usage, or relative body mass index [23].

## **2.12 Deep Learning for ECG Classification**

Because of numerous contemporary medical applications where this problem may be mentioned, the necessity of ECG classification is presently quite high. Many machine learning (ML) techniques are already available for evaluating and categorizing ECG data. However, the use of hand-crafted algorithms or manufactured features with shallow feature learning architectures is one of the key drawbacks of these ML outcomes. The issue stems from the probability that the most appropriate characteristics may not be found in this ECG condition, resulting in low classification accuracy. One proposed option is to employ deep learning architectures, in which the initial layers of convolutional neurons operate as feature extractors, while the last levels of fully connected (FCN) layers are used to make the final choice regarding ECG classifications. This paper presents a deep learning architecture for ECG classification that includes 1D convolutional layers and FCN layers, as well as some classification results [24].

## **2.13 Internet of things: A survey**

The Internet of Things (IoT) has attracted the attention of academic interest over the last year. The Internet of Things, often known as IoT, is a component of the Internet of the Future that will be made up of billions of 'things' that are capable of

intelligent communication with one another. The Internet of the future will be made up of a variety of different devices that are all linked together. These devices will expand the boundaries of the world by adding both real and virtual items. The Internet of Things (IoT) will grant newly developed capabilities to interconnected things. The definitions, architecture, underlying technologies, and applications of the Internet of Things are thoroughly covered in this overview [25].

## **2.14 Research On the architecture of Internet of Things**

The Internet of Things (IoT) is a technological revolution that will shape computers and communications in the future. It is not only an Internet or Telecommunications Network extension. It has characteristics of both the Internet and the Telecommunications Network, as well as its own unique characteristics. We propose that the existing recognized structure of the Internet of Things can't describe the entire features and meaning of the Internet of Things by analyzing it. By reanalyzing the technical foundation of the Internet and the Telecommunication Management Network's Logical Layered Architecture, we establish a new five-layer architecture for the Internet of Things. We believe that this design will make it easier to grasp the essence of the Internet of Things, and we hope that it will aid in its development [26].

## **2.15 The Internet of Things – a promise for the future?**

The Internet is a functioning, breathing system that evolves and grows all the time. New applications and organizations are being developed all the time. The landscape is shifting as a result of developments in technology and the expansion of the internet. Broadband connectivity is becoming more accessible at a lower cost and is expanding in scope, while devices that include a range of on-board sensors are becoming more capable and more compact. The proliferation of devices that can link

to one another has stated rise to a new concept: the Internet of Things. The potential to extend the scope of the Internet to include physical objects, in addition to the capability to provide improved functionality to the systems as more data becomes available, is the driving force behind the development of the Internet of Things. The ideas underlying the Internet of Things are applied in a wide number of application fields, from green information technology and energy efficiency to the field of logistics. There are problems associated with the Internet of Things, the most prominent of which are in the fields of trust and security, standardization, and governance. These problems need to be solved in order to develop an Internet of Things that is trustworthy, open, and equitable, and that provides benefits to everyone. The Internet of Things (IoT) ranks highly on the research agendas of a number of different companies, as well as the European Commission and numerous governments, such as China's. The findings are providing direction for the construction of an Internet of Things that is robust and user-friendly. The Internet of Things offers enormous benefits to developing countries and economies that are only beginning to emerge, and it is imperative that plans be established to take use of these advantages [27].

## **2.16 The Internet of Things: An Overview Understaing The Issues and Challenges of a More Connected World**

The Internet of Things, which is also referred to as IoT at times, is a subject that is garnering a lot of attention not just in the engineering and policy communities, but also in the IT sector. In addition to this, it is making news in both the industry press as well as the general press. This technology may be found in a broad variety of networked devices, systems, and sensors. These technologies make use of recent advancements in computing power, reductions in the size of electronic components, and network linkages in order to give capabilities that were previously unobtainable. Numerous conferences, articles, and news stories have been devoted to investigating and debating the potential repercussions of the so-called "revolution of the Internet of Things." These events have taken place throughout the course of the past several years. These

repercussions include a wide variety of topics, including new business models and market possibilities, as well as worries about technological interoperability, security, and privacy [28].

### **2.17 Internet of Things (IoT) for Next-Generation Smart Systems: A Review of Current Challenges, Future Trends and Prospects for Emerging 5G-IoT Scenarios**

Significant developments in wireless sensing devices, telecommunication, and informatics have enable pervasive intelligence, which represents the future Internet of things (IoT).The concept of interconnected devices, which intended to fully integrate into people's daily lives, dates back to the 1980s, which would also be when the Internet of Things got its start.At the moment, people are thinking about the Internet of Things on a personal level as well as on a professional level.E-health, smart housing, and smart learning are all examples of areas in which the Internet of Things (IoT) individually plays an important part in elevating living standards.Professionals have a variety of applications for Internet of Things technology, Robotics, intelligent supply - chain management and transport, remote patient monitoring, and logistics are all just a couple of minor topics covered. Ericsson predicts that by the year 2021, there will be around 28 billion smart devices linked all over the world. Additionally, machine-to-machine communication (also known as M2M communication) is used by more than 15 billion different devices. Another set of studies predicts that by the year 2020, individuals would carry roughly six to seven electronic gadgets per person[29].

### **2.18 IoT security: Review, blockchain solutions, and open challenges, Future Generation Computer Systems**

With the development of smart homes, smart cities, and smart everything, the Internet of Things (IoT) has risen as a sector with significant promise. Cisco Inc. estimates that there will be 50 billion linked devices by the year 2020. On the other hand, the vast majority of these Internet of Things devices may be easily hacked and corrupted. These Internet of Things devices often have smaller capacity for compute,

storage, and networks, which makes them more susceptible to assaults than other endpoint devices such as laptops, tablets, and smartphones.

We discuss IoT security requirements, as well as current attacks, threats, and cutting-edge solutions. In addition, we compile a list of IoT security issues and relate them to the literature's current solutions. More significantly, we demonstrate how blockchain, the technology which underlies bitcoin, may be utilized to identify a variety of IoT security issues. In addition, the article addresses open research concerns and challenges in the field of IoT security. [30]

## **2.19 IoT Middleware: A Survey on Issues and Enabling Technologies**

The Internet of Things enables humans and computers to understand and react through billions of things, including sensors, actuators, applications, and other Internet-connected devices (IoT). IoT technology will enable complete connection of the virtual and real worlds, dramatically transforming and boosting human contact with the earth. A vital component in the creation of IoT systems is middleware, which is generally characterized as a software system meant to act as a mediator for IoT devices and applications. We demonstrate the significance of an IoT middleware in this paper by exhibiting an Application prototype for human blood alcohol content prediction using portable sensor data. After that, a survey of existing IoT middleware's capabilities is undertaken. We also look at the challenges and enabling technologies in creating IoT middleware that supports the key parts of composition, adaptability, and privacy in an IoT system while embracing the diversity of IoT devices [31].



## **2.20 IoT Network Security: Threats, Risks, and a Data-Driven Defense Framework**

The recent spike in Internet of Things (IoT) adoption has accelerated integration and expanded the Internet's reach beyond ranging from desktops, laptops, and mobile devices to a vast variety of tangible items. The Internet is becoming increasingly intertwined with ordinary life with each passing day, thanks to the Internet of Things. Despite the fact that Internet of Things devices make life easier and offer limitless new capabilities, they also substantially increase the opportunity for malicious individuals, criminal organizations, and even state actors to spy on and interfere with the activities of innocent Internet of Things users. In this research, we make use of an analytical technique to investigate the potential risks connected with Internet of Things (IoT) systems, and we then present a solution that is based on machine learning and is intended to categorize and recognize IoT attacks. Using a real-world IoT system that has regulated gate access as a platform, we provide a comprehensive overview of the Internet of Things (IoT) system, which includes functionality to log potential or actual security breaches. We use data that was collected over a period of nine months as our testbed in order to conduct an analysis on the accuracy of predictive models that have been taught by machine learning. Based on this analysis, we propose design principles as well as a general framework for the construction of safe Internet of Things systems [32].

## **2.21 Internet of things (IoT) security: Status, challenges and prospective measures**

The article provides an overview and evaluation of the present state of Internet of Things (IoT) cybersecurity as well as the issues that it raises. The Internet of Things (IoT) architecture is designed to link everyone with anything at any time. The three levels of IoT architecture are perception, network, and application. Several security

criteria must be enforced at each layer to establish a safe IoT solution. By only identifying and resolving the IoT framework's security issues will the framework's future be guaranteed. Many academics have attempted to build remedies to identify and prevent weaknesses that are unique to IoT layers and devices. The goal of this article is to give a high-level overview of cybersecurity issues, technology and security challenges, potential solutions, and future views for securing the Internet of Things [33].

## **2.22 IoT and cloud convergence: Opportunities and challenges**

The IoT world's success depends on the availability of services that are characterized by ubiquity, dependability, high performance, efficiency, and scalability. To achieve this attribution, future business and research visions are to combine Cloud Computing and IoT principles, enabling a "Everything as a Service" model: particularly, a Cloud ecosystem will be supplied, comprising unique functionality and cognitive-IoT capabilities. As a result, the article will explain a novel IoT-centric Cloud smart architecture that addresses specific IoT and Cloud Computing issues [34].

## **2.23 IoT Healthcare: Benefits, Issues and Challenges**

A sportsman's watch no longer just tells the time; it also tells you where you are in the world, how many steps you've taken, your heart rate, blood oxygenation, blood pressure, and so on. An "elderly person's bracelet may measure numerous physiological indications and communicate them in real time to her doctor, enabling him to check her health even if they are not in the same location." As a result of the incorporation and use of sensors, watches and wristbands have evolved into smart objects. The Internet of Things (IoT) has made its way into the health industry, with products that can "watch" our bodies flooding electrical store shelves [35].

## **2.24 Healthcare IoT**

There is a long history of collaboration combining technology and healthcare. With the emergence of small wearable biosensors and research advancements in Big Data approaches for efficient manipulation of huge, multiscale, bidirectional, distributed, and heterogeneous data sets, the Internet of Things (IoT) concept has witnessed tremendous expansion and acceptance in recent years. This advancement has expanded the scope of individualized healthcare services. The Internet of Things has ushered in a paradigm change in healthcare, bringing benefits including accessibility, availability, personalized information, and cost-effective delivery. While the Internet of Things has increased the number of alternatives for meeting healthcare demands, there are still a few challenges to solve in order to build adaptable, appropriate, energy, and safe health-care systems. To make this change possible, the software and hardware teams will need to work together to make substantial technological advancements. This chapter on breakthrough IoT technologies for smart healthcare covers wearable sensors, body area sensors, advanced ubiquitous medical systems, and Big Data analytics. It identifies fresh perspectives while highlighting appealing research issues and challenges such as sustainability, accessibility, device-network-human interfaces, and security. Finally, a new case study, ECG-based arrhythmia diagnosis, analyzes the applicability of healthcare IoT using machine learning and neural network model (CNN) methodologies dispersed over Edge-Fog-Cloud [36].

## **2.25 An implementation of IoT for healthcare**

The Internet of Things (IoT) is a technological process in which every physical device is linked with detectors, microcontrollers, and transceivers to allow communication, and is built with appropriate protocol suite to allow them to communicate with one another and interact with humans. This enables physical items to exchange data and information with one another as well as with humans. IoT-based healthcare allows for the collecting, storage, and analysis of massive quantities of data in novel ways, as well as the activation of context-based alerts, by aggregating, analyzing, and communicating real-time medical information to the

cloud through a network of scattered devices. This one-of-a-kind data collection paradigm allows for continuous and universal access to medical technologies such as The internet from any connected device. Because each IoT device's battery capacity is limited, it's important to cut power consumption to help the healthcare system last longer. This article explains how to utilize the ZigBee mesh protocol to create an Internet of Things-based in-hospital healthcare system. The design of a medical system enables for regular monitoring of in-hospital patients' physiological data [37].

## **2.26 Design and implementation of interoperable IoT healthcare system based on international standards**

The power supply, CPU capacity, memory, and network management of IoT devices in an IoT ecosystem are all limited. Bandwidth, wireless channel, throughput, payload, and other restrictions can be divided down into groups. These resources, on the other hand, may well be decided to share with other Smart objects. The management and accessibility of patient-related and device information are critical in the framework of internet of things healthcare services. Based on the ISO/IEEE 11073 PHD (Personal Healthcare Device) and CoAP (Constrained Application Protocol) standards, we propose the design and implementation of an Internet of Things healthcare system in this work. The purpose of this system is to increase interoperability and prevent data loss among devices and during transfer of measured data. We developed a performance comparison between HTTP and CoAP in terms of the number of packets in a single transaction, the number of packets by data loss rate during transmission, and a syntax use comparison between XML and JSON to show the recommended design. This assessment analyzes the amount of packets in a single exchange, the number of packets divided by the loss of data rate during transmission, and syntax use [38].

## **2.27 IoT for Healthcare**

(IoT) is a network of physical objects or things that can gather and share data and are combined with electronics, computers, sensors, and network connectivity. The Internet of Things allows for the remote sensing data and control of objects via current network infrastructure. Recent advancements in RFID, sensor technologies, modern communications, and Internet protocols have enabled the Internet of Things. The underlying idea is that smart sensors will work together to generate a new class of applications without the need for human interaction. The IoT's initial phase might be regarded the current Internet, mobile, and machine-to-machine (M2M) revolution. In the coming years, the Internet of Things (IoT) is expected to connect various technologies to enable software innovations by connecting physical objects to improve intelligent decision-making. Smart healthcare plays an important part in healthcare applications by integrating sensors and devices in consumers and their medications for tracking and monitoring purposes. The Internet of Things is used in clinical care to check patients' physiological status via sensors, gather information about their data, and then transfer the analyzed data to processing facilities for necessary action. Regular people, not only patients, can benefit from using wearable gadgets with sensors to monitor their health [39].

## **2.28 A Wearable, Low-Power, Real-Time ECG Monitor for Smart T-shirt and IoT Healthcare Applications**

Wearable health monitoring combined also with Internet of Things (IoT) would be a feasible replacement for traditional healthcare. This research presents a compact, flexible, and wearable real-time electrocardiograph (ECG) measuring device built into a T-shirt. It uses an off-the-shelf biopotential analog front end (AFE) chip named AD8232 to capture ECG data from humans. The collected ECG data is transferred via Bluetooth low energy (BLE) to an end device for real-time display. A PC user interface (GUI) and a mobile application have been created for interior and

exterior real-time visualization. The proposed wearable ECG monitoring device may operate as low as 5.2 mW. A 240 mAh rechargeable battery allows it to operate for even more than 110 hours of battery life. This device also includes a foldable solar energy generator to help extend the battery's life [40].

## **2.29 An Investigation on IoT Healthcare Analytics**

The Internet of Things transforms objects into active participants, allowing them to communicate with one another and exchange data. It has numerous applications in a variety of fields, including healthcare. The Internet of Things is changing the way healthcare is delivered to individuals. It fosters a positive interaction between doctors and patients, resulting in high-quality medical care. These are accomplished by using sensors to continuously monitor patients. The information gathered is saved and will be used for future analytics. The analytical solution in healthcare data opens up the possibility of disease detection. This article discusses the Internet of Things in healthcare and the technology that supports it.

The structures and services involved in medical care solutions are discussed in this study. The technique of healthcare analytics, as well as the data sources used in analytics, are also discussed. It is investigated by many algorithms that are involved. It also examines the different difficulties that face healthcare [41].

## **2.30 Internet of Things (IoT): A Review of Its Enabling Technologies in Healthcare Applications, Standards Protocols, Security, and Market Opportunities**

The Internet of Things (IoT) is a technique or system that uses networking technology to connect and communicate with real-world items. This article examines current technologies and includes polls on IoT-based healthcare procedures that have improved. Furthermore, this study classifies a current IoT-based health network and describes all possible networks. IoT healthcare processes are reviewed in this context, and a comprehensive discussion is addressed. It also marks the start of a worldwide

study on IoT health apps and services. In IoT surrounds healthcare, extensive insights on IoT healthcare security, its requirements, problems, and privacy issues are visualized. This review proposes an IoT-based security architecture model to address the security issues. Furthermore, this study reveals a market potential that will boost the growth of the IoT healthcare market [42].

### **2.31 The working principle of an Arduino**

This article takes a look at the fundamentals of how an Arduino board functions. The Arduino platform is drawing a growing number of people because to its simplified version of C++ and fully prepared Arduino microcontroller (atmega328 microcontroller [1]) which can be reprogrammed, erased, and written at any moment. This article will discuss the physical components that are used in the Arduino board, the software that is required to program it (the Arduino board), a tutorial on how to develop and construct your own projects, as well as a few examples of projects that were created using Arduino, and it will also include some examples of Arduino projects. After reading this article, you will have a general understanding of what an Arduino Uno is and how it may be used because it will offer you with an overview of the device in its entirety [43].

### **2.32 Arduino as a learning tool**

We'll look at the Arduino and some of its uses, as well as how it might be utilized in education, in this article. Arduino is a microcontroller that is open-source and used for electronic prototyping. The hardware and components of the Arduino will be examined. Both the software and the environment in which Arduino runs are examined. Some examples of applications that might help make learning Arduino more appealing will be used. This might be a great approach to get students and others interested in learning more about electronics and programming [44].

### **2.33 Influence of Arduino on the Development of Advanced Microcontrollers Courses**

This paper describes the evolution of digital design classes that use Arduino boards as their primary platforms. Arduino provides a user-friendly development environment as well as a variety of hardware and software tools for developing microcontroller-based projects quickly. Due to the large amount of information available, students, on the other hand, were lacking the right to design their own models. It proposes a method that starts with a look at microcontrollers and how to use Arduino to make various creations, then moves on to a look at system architecture to get control of the device. A microcontrollers bachelor's class and a graduate course on modern digital design approaches have both used this methodology. Students in the advanced techniques in digital design course were able to learn about integrated system hardware/software co-creation by using the Arduino platform [45].

### **2.34 Study of Arduino microcontroller board**

In this lecture, we will cover the principles behind the working of the Arduino microcontroller as well as its applications. In addition to this, it will show how the Arduino microcontroller may be exploited in this article as a tool for research and study. The Arduino microcontroller makes it possible to rapidly develop applications based on extremely small sensors. The Arduino microcontroller is easy to grasp and straightforward to program. Programming the Arduino microcontroller is made possible using the software called IDE. A tool for developing programs that may be used with Arduino boards is called the Arduino IDE. You are free to download and install the open-source software known as the Arduino IDE on your personal computer at no cost. The Arduino Integrated Development Environment (IDE) includes a selection of libraries that are already configured for usage. If Arduino programmers use these libraries, they will cut a significant amount of programming time from their projects. This article goes through the many varieties of Arduino boards, the underlying operating principles, the software implementation, and the applications of Arduino [46].



### **2.35 Open-Source Hardware Is a Low-Cost Alternative for Scientific Instrumentation and Research**

The gathering of data is an essential aspect of scientific study, since it enables researchers to investigate, monitor, assess, investigate, explain, or grasp a certain process or occurrence. Automating the process of data collection can cut down on the amount of manual work that is needed and boost the frequency of measurements, but this comes at the expense of increasing expenses connected with electronic data-gathering apparatus. Because manually taking measurements may be both time-consuming and labor-intensive, this method of data collection may not be used as frequently as it otherwise would be. Arduino is an Open Source Hardware project that includes a development platform for programmable microcontrollers, add-on boards for expansion, and a programming environment for the generation of bespoke software for programmable microcontrollers are all included. These components are all part of the Arduino ecosystem. All of the technical specifications for the circuit boards and electrical components, in addition to the programming tools, are open-source, meaning that anybody is allowed to use or change them [47].

### **2.36 Research on IoT Privacy Security Risks**

As the Internet of Things (IoT) is gradually implemented, people's lives are getting more and more convenient. However, when people take advantage of the conveniences provided by the Internet of Things, there are some hazards to their privacy and security. Providing convenience while also reducing danger appears to be a long-term endeavor. How might this be accomplished? It was from this perspective that the article looked at the root causes of privacy and security problems and proposed some practical IoT risk mitigation strategies. These research findings have some definite practical applicability, and they would serve as an important theoretical reference in the field of scientific research and engineering if they were to be implemented [48].

### **2.37 Data Security and Privacy in the IoT**

Traditional data security solutions are hard to apply to the Internet of Things (IoT) due to the wide variety of components, highly dynamic and potentially vulnerable environments, and large scale of the IoT. This article highlights directions for future research for trying to secure Internet of Things information, such as efficient and scalable data encryption, software protection methods for small devices, and perfectly alright data packet loss analysis for sensor networks, after highlighting the huge problems in data security and privacy [49].

### **2.38 A view on privacy & trust in IoT**

With the rise of Internet of Things (IoT) technology, not only in industrial and commercial contexts, but also in our daily lives using smart gadgets at home, the technology is quickly gaining popularity. Such gadgets are frequently interconnected with cloud services, which offer ease of use as well as worldwide accessibility. Managing the balance between confidence in the service provider and the requirement for individual privacy, on the other hand, becomes a significant difficulty when contemplating the automated sharing of a plethora of personal information. Here, it suggests an automated mapping between the concepts of information, privacy, and trust, all while keeping the user's ability to influence the mapping process [50].

### **2.39 A Medical Healthcare System for Privacy Protection Based on IoT**

The evolution of health care information and communications technology is undoubtedly aided by the growth of IoT technology. Privacy protection has become a barrier inside the delivery of smart medical care in the current day, despite the fact that it has been thoroughly investigated and acknowledged. As a result, the subject of how to protect users' personal details in a digital healthcare system remains a point of controversy. In light of this, this research looks at the major difficulties that the current smart healthcare system faces. In addition, an encryption method is given in this study, which takes into account the peculiarities of the Internet of Things and privacy laws [51].

## **2.40 Fundamentals for IoT networks: secure and low-latency communications**

The expanding Internet of Things has various unique characteristics that differentiate this apart from existing wireless network infrastructure, such as the ones listed below. The use of primary applications for data gathering, inference, and control, as well as the deployment of many low-complexity terminals, the requirement for low-latency, short-packet communications, the use of minimal or no infrastructure, including the use of primary applications for data gathering, inference, and control, are just a few examples. Researchers are working on the creation of new basics that can offer insight into the communication restrictions in this regime as a result of these qualities. This paper discusses two issues in this setting, namely security and low latency [52].

## CHAPTER 3

### HEALTH PATIENT MONITORING SYSTEM

Health Monitoring can provide useful data in the home. This monitoring is beneficial for elderly or chronically unwell individuals who do not want to stay in the hospital for an extended period of time. Wireless sensors can detect and transmit messages of interest, which are automatically processed and analyzed by a processor. In this project, I will select relevant sensors based on what you want to detect and create algorithms to implement your detection.

The project's goal was to develop a system that could remotely monitor and deliver physiological data in the home. The monitoring device might be beneficial to elderly or chronically unwell people who want to avoid a lengthy and expensive hospital stay. Wireless sensors would gather and broadcast signals of interest, and a microcontroller would receive and interpret the sensor signals automatically.

It was critical that devices that require immediate intervention by a specialized doctor be autonomous and non-invasive to the patient's or user's daily activities. They were to be simple to use, small and light, consume less power for longer battery life, and functional-able to sustain physical stress in the event of a fall detection.

The circuitry in the detecting system was critical in both situations for accurate physiological signal detection. Integrated circuits and microprocessors were used to accurately gather and manage the signal information. This was done to reduce drift voltages and any white noise that the detection system might pick up.

### **3.1 Feasibility**

The purpose of my project is to create an independent system that will monitor and will provide useful information directly on the internet. The system will be very useful for elderly people that need attention 24 hours. The sensors will be wireless sensors and will be used to take inputs from the body of the patient and the controller will be programmed to analyze the information given by the sensors.

The system that I will present it aims to be a wearable system.

For a system that needs instant actions by a doctor it is important to be an autonomous system. I must design a system in that way that can be small in size, light in weight and also consume less power in order to avoid overusing the battery. The patient can wear the system and will be connected to the Wi-Fi so it can transmit data directly to the internet and directly to the family member or the doctor that is monitoring the patient.

The aim of the project is to create a system that can monitor and send biomedical signals in the house remotely. The monitoring device might be beneficial to elderly or chronically unwell people who want to avoid a lengthy and expensive hospital stay. Wireless sensors would gather and broadcast signals of interest, and a microcontroller would receive and interpret the sensor signals automatically.

It was critical that devices that require immediate intervention by a specialized doctor be autonomous and non-invasive to the patient's or user's daily activities. They were to be simple to use, small and light in size and weight, consume less power for longer battery life, and be functional - able to withstand physical stress in the case of fall detection. The circuitry in the detecting system was critical in both situations for accurate physiological signal detection. To be able to acquire and manage signal data with precision Microprocessors and integrated circuits were used. This was done to reduce drift voltages and any white noise that the detection system might pick up.

### **3.2 Ethical Issues**

Because of the vulnerabilities of devices that connect to the internet, the sensitive nature of health-related data, and the influence that it will have on healthcare delivery, the Internet of Things (IoT) has the potential to improve healthcare delivery, but it also poses a number of ethical challenges. In the medical profession, the Internet of Things is designed to work for both public and private worlds at the same time. The sensors and equipment may either be carried about by a person or installed within locations such as hospital wards, a house, or a place of employment. Because of the nature of these circumstances, it may be possible for a third party to gather information about the actions or health state of an individual and analyze that information. Even if healthcare is getting better because to remote monitoring and faster reaction times, the very nature of the technology involved creates chances for breaches of privacy, either of the patient's personal information or of the patient's medical records.

Additionally, it has been observed that the application of IoT in healthcare might have an effect on the provision of healthcare services. IoT devices that are less invasive, such as wristbands or armbands, are being used to give older people more control over their own medical care. This is being done in an effort to preserve the elderly's feeling of autonomy, which is especially important in their latter years. This results in fewer visits from medical professionals and increases the likelihood of social isolation due to the fact that monitoring may be performed remotely.

The top ethical issues in health care monitoring system in my opinion are as below:

- Confidentiality
- Privacy
- Data sharing
- Surveillance

## CHAPTER 4

### METHODOLOGY

The thermistor sensor would be used to measure the patient's body temperature. The sensor clearly shows a change in resistance in corresponding to changes of the body temperature. The temperature sensor is attached to the patient, will change the values and the body temperature is measured and graphically displays those values.

A pulse wave is the change in volume of a blood vessel that changes when the heart pumps blood in the body. A photoelectric sensor is used to measure the patient's pulse rate. This sensor is called heart beat sensor. We can also use a photoplethysmography sensor (PPG) to measure heart rate. PPG is a technical term for shining light into the skin and measuring the amount of light that is reflected by blood flow.

ECG sensor or in other words piezoelectric sensors are used to measure pressure, acceleration and convert to electrical signals.

Temperature sensors are integrated sensors as LM35 and their voltage is linearly proportional to Celsius temperature. The accuracy of the sensor is  $\pm 1/4$  degree Celsius at room temperature and  $\pm 3/4$  degree Celsius on a range of  $-55$  to  $+150$  degree Celsius.

## CHAPTER 5

### TOOLS NEEDED

#### 5.1 Arduino Mega 2560

The Arduino Mega has 16 analog pins, 54 digital pins, a power port, a USB port, a reset button and 4 hardware serial pins.

The Arduino board can operate on a 6 to 20V power supply. If we supply the board with less than 7V, the pins that use 5V will supply less power on those 5V pins and therefore the board may be unstable. Also if we apply more than 12V than the voltage regulator will overheat and will damage the chips on the Arduino. The voltage recommended range is 7 to 12V.

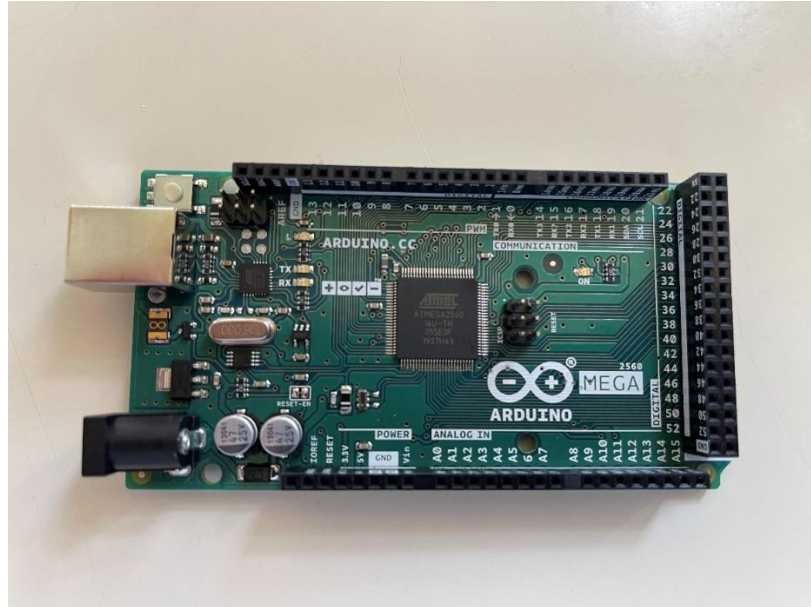
The power pins are described below:

**VIN** → This pin is the Arduino board's regulated power supply, that powers the microcontroller and other components. It can be powered through the Vin pin or using a traditional power jack with an adapter.

**5V** → This pin has been used to power the microcontroller or other components on the Arduino board using a regulated power source.

**3.3V** → This pin can generate a 3.3V by using the regulator chip. The maximum current from this 3.3V pin is 50mA.

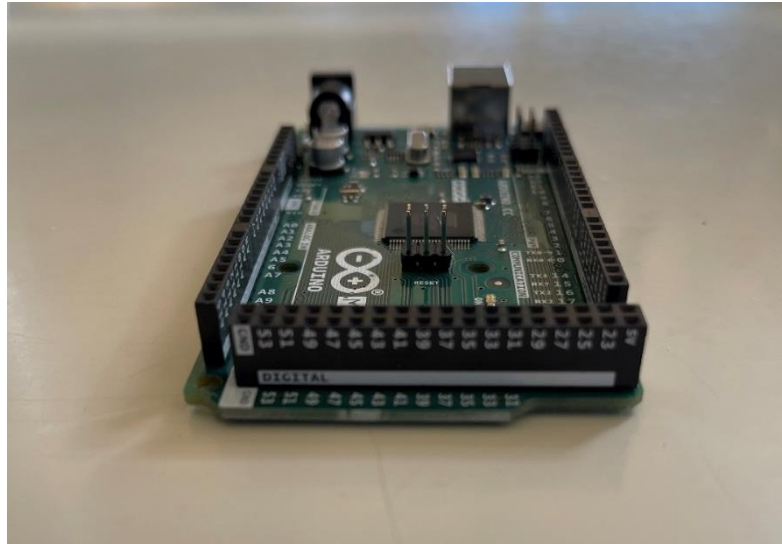




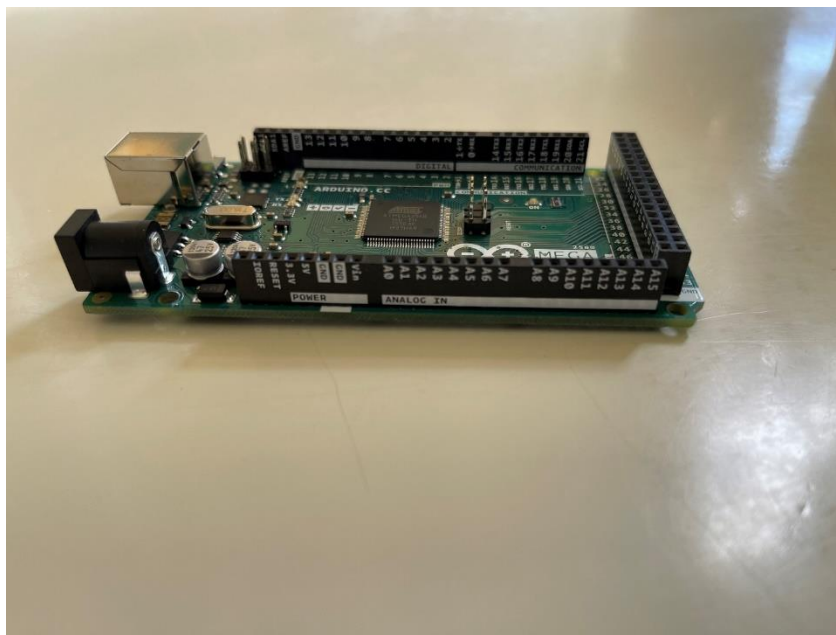
*Figure 3: Top view of Arduino Controller*



*Figure 4. Side view of Arduino Controller 1*



*Figure 5.*Side view of Arduino Controller 2



*Figure 6:* Side view of Arduino Controller 3



**Figure 7:** Side view of Arduino Controller 4

## 5.2 GSM Module

SIM800L GSM module is a small GSM module which can be used in many IoT projects. The module can be used for example to make a normal call, to send SMS messages, connect to internet through TCP/IP and more.

The operation voltage for this module is from 3.4V to 5V.

It supports baud rate from 1200bps to 115200bps.

The module needs an antenna to connect to a network and uses a normal microSIM card.

Supports Quad-band: GSM850, EGSM900, DCS1800 and PCS1900.

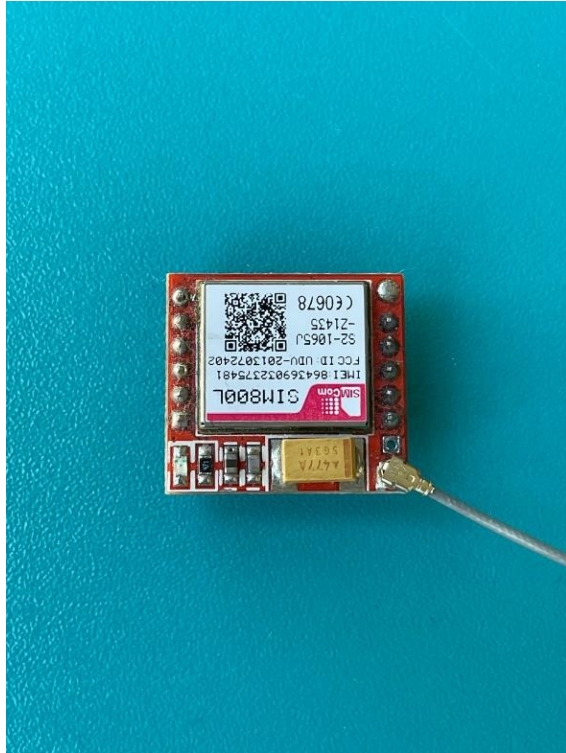
Send and receive SMS messages.

Send and receive GPRS data

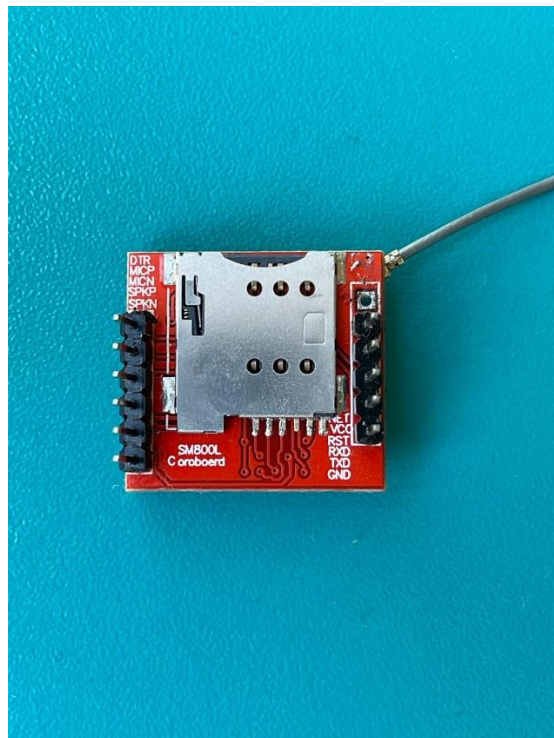
Serial-based AT Command Set

On top of the module is a small LED which indicates the status of the network.

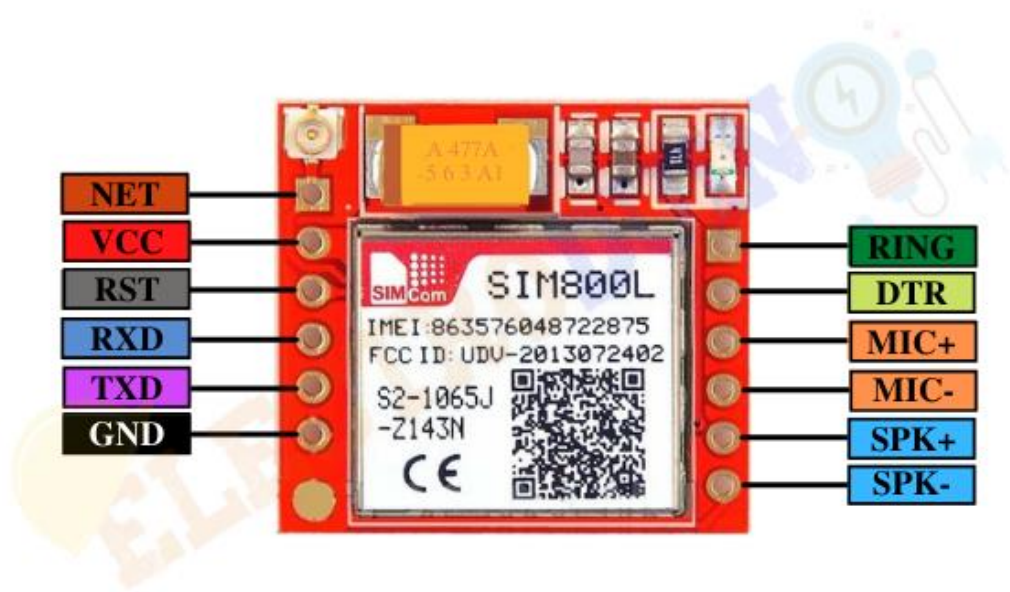
- If it blinks every 1 second, means that the module is running but hasn't made connection to the cellular network yet.
- If it blinks every 2 seconds means that the module is connected.
- If it blinks every 3 seconds the module has made contact with the cellular network.



*Figure 8:* Top view of GSM Module SIM800



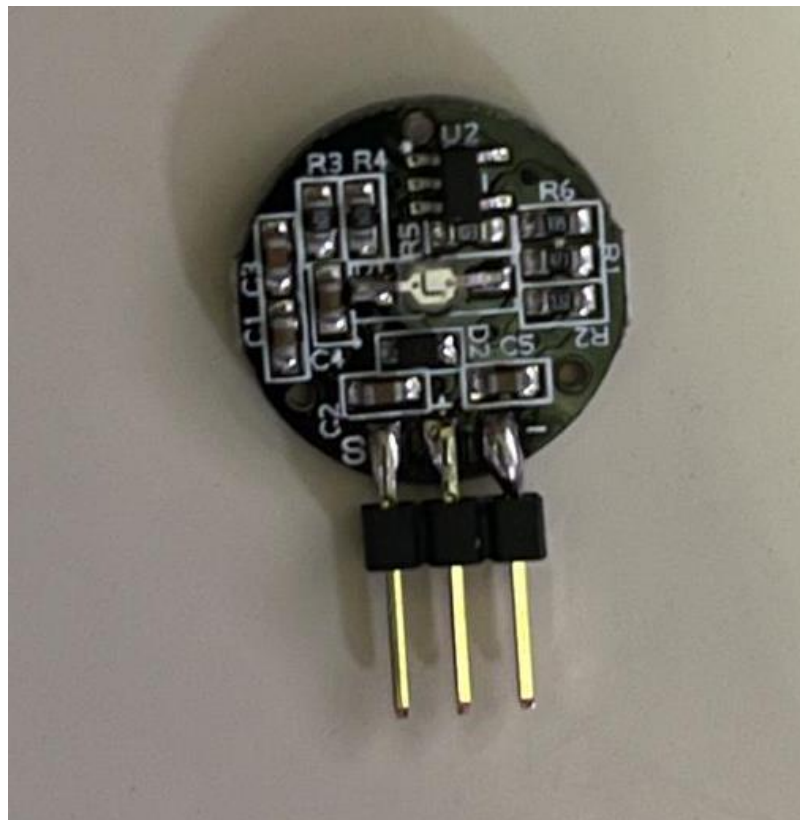
*Figure 9 :* Bottom side of GSMi Module SIM800



*Figure 10:* Pinout diagram of GSM module SIM800.

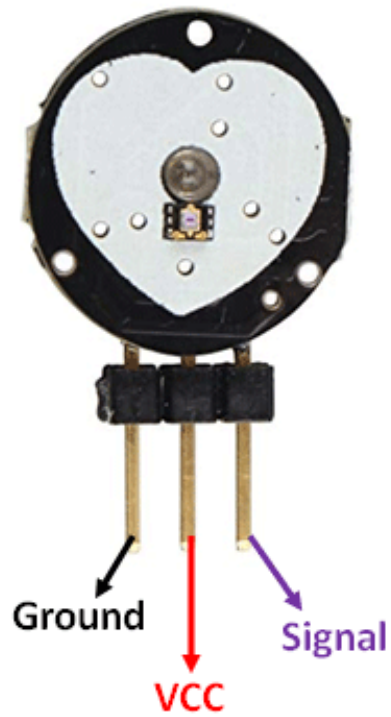
### 5.3 HeartBeat Sensor

A heart sensor will be used to assess the heart rate based on our blood flow. A heart sensor is a device that measures heart rate, or the rate at which the heart beats. The Heartbeat Sensor will give a simple way of determining the heart's function, which can be detected using a psycho-physiological signal. Our blood flow changes with the flow of time. The sensor will measure the light that is passed to the light dependent resistor by using a bright LED.

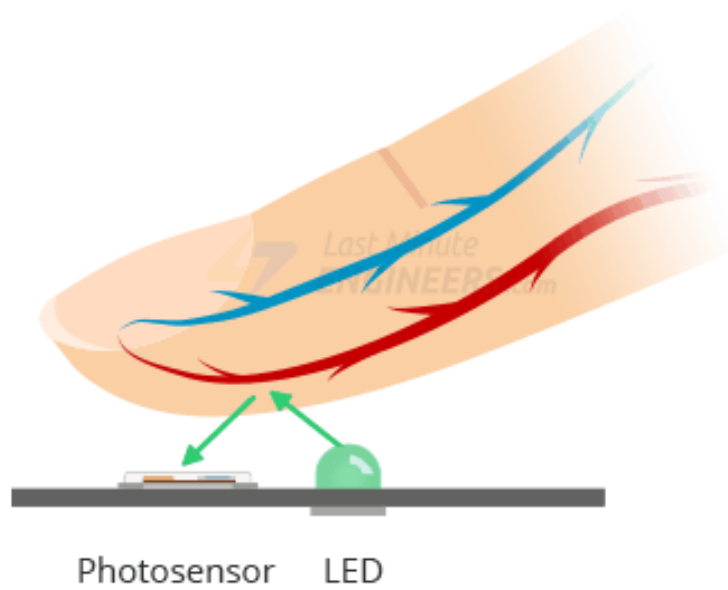


*Figure 11: Heart Beat Sensor*





*Figure 12:* Pinout diagram of pulse sensor



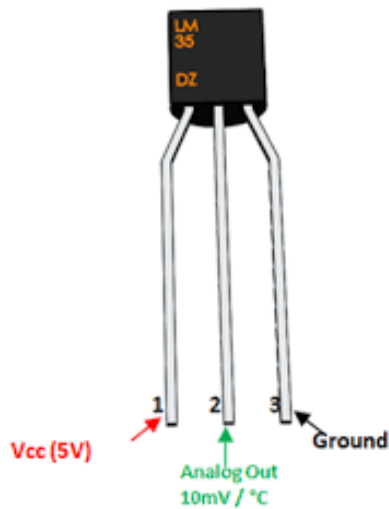
*Figure 13:* Pulse detection method through light called Photoplethysmogram



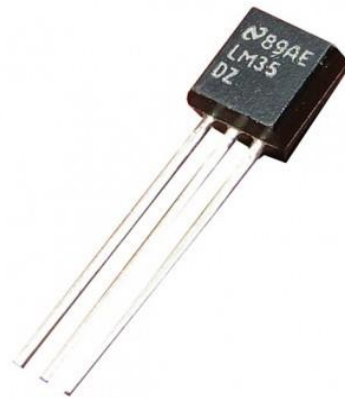
## 5.4 Temperature sensor LM35

The LM35 sensor is one sort of commonly used temperature sensor that may be used to measure the temperature using an electrical output related to the temperature (in degrees Celsius). It can deliver more precise temperature measurements when compared to a thermistor. Because this sensor produces a greater voltage output than thermocouples, amplification of the output voltage may not be required to achieve the desired result. Features of LM35 are as shown below:

- Has only one port pin for communication
- Can be powered from the data line
- Power supply range is 3.0V to 5.5V
- Measures temperature from -55 °C to +125 °C with 0.5 °C accuracy from -10 °C to +85 °C
- Converts temperature to 12-bit digital word in 750ms(max)

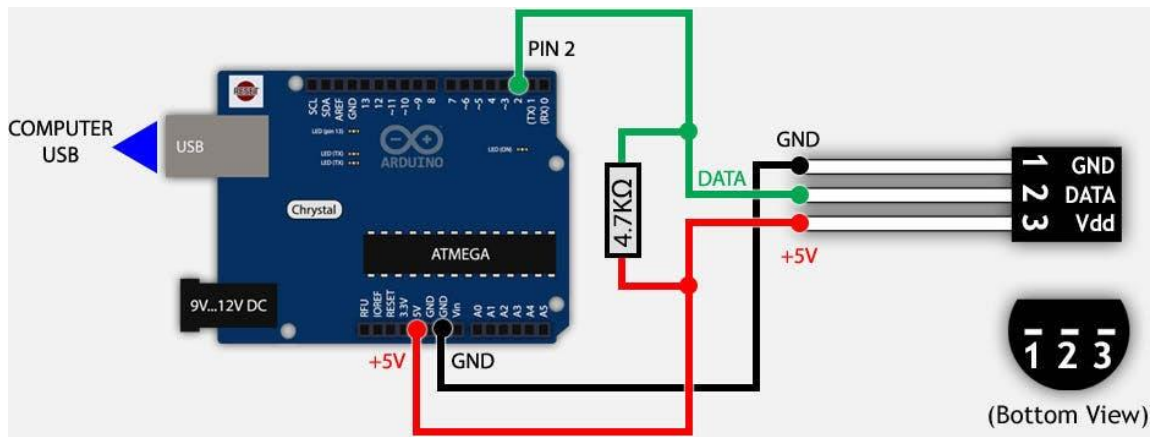


*Figure 14:* LM35 Pinout



*Figure 15:* LM35

I didn't find the DS18B20 but I built it using a LM35 and a 4.7kohm resistor.



*Figure 16:* DS18B20 circuit diagram using LM35 and resistor

## CHAPTER 6

### IMPLEMENTATION IN PRACTICE

Code used for this project is as below:

```
#define USE_ARDUINO_INTERRUPTS true //--> Set-up low-level interrupts for
most accurate BPM math.

#include <PulseSensorPlayground.h> //--> Includes the PulseSensorPlayground
Library used for pulse sensor

#include <LiquidCrystal_I2C.h> //--> Includes the LiquidCrystal Library used of LCD

LiquidCrystal_I2C lcd(0x27,16,2); //-->0x27 address of lcd,pin connection for lcd

#include "DHT.h" //--> Includes the DHT Library

#include <SoftwareSerial.h> // -->Includes the software serial Library used for
communications

SoftwareSerial gprsSerial(3,2); //--> Define connection pins of GSM module

#define DHTPIN A1 //--> Define connection pin of DHT11

#define DHTTYPE DHT11

DHT dht(DHTPIN, DHTTYPE);

const int PulseWire = A0; //--> PulseSensor connected to ANALOG PIN 0

int LED_3 = 4; //--> LED to detect when the heart is beating. The LED is connected
to PIN 3 on the Arduino UNO.

int Threshold = 550;
```

```
byte heart1[8] = {B11111, B11111, B11111, B11111, B01111, B00111, B00011,
B00001};
```

```
byte heart2[8] = {B00011, B00001, B00000, B00000, B00000, B00000, B00000,
B00000};
```

```
byte heart3[8] = {B00011, B00111, B01111, B11111, B11111, B11111, B11111,
B01111};
```

```
byte heart4[8] = {B11000, B11100, B11110, B11111, B11111, B11111, B11111,
B11111};
```

```
byte heart5[8] = {B00011, B00111, B01111, B11111, B11111, B11111, B11111,
B11111};
```

```
byte heart6[8] = {B11000, B11100, B11110, B11111, B11111, B11111, B11111,
B11110};
```

```
byte heart7[8] = {B11000, B10000, B00000, B00000, B00000, B00000, B00000,
B00000};
```

```
byte heart8[8] = {B11111, B11111, B11111, B11111, B11110, B11100, B11000,
B10000};
```

```
//-----
```

```
int Instructions_view = 500; //--> Variable for waiting time to display instructions on
LCD.
```

```
PulseSensorPlayground pulseSensor; //--> Creates an instance of the
PulseSensorPlayground object called "pulseSensor"
```

```
void setup() {
```

```
  gprsSerial.begin(9600);          //--> the GPRS baud rate shpejtesia e gsm ne baud
  rate
```

Serial.begin(9600);/--> Set's up Serial Communication at 9600 speed. vendos komunikimin serial ne shpejtesin 9600 baud rate

lcd.init(); //--> Initializes the interface to the LCD screen, and specifies the dimensions (width and height; x and y) of the display

lcd.backlight(); //--> inicializon backlight

dht.begin();

//-----Create a custom character for use on the LCD

lcd.createChar(1, heart1);

lcd.createChar(2, heart2);

lcd.createChar(3, heart3);

lcd.createChar(4, heart4);

lcd.createChar(5, heart5);

lcd.createChar(6, heart6);

lcd.createChar(7, heart7);

lcd.createChar(8, heart8);

//-----

lcd.setCursor(0,0); // -->position cursor to row 0 position 0

lcd.print("Sistem Monitorimi "); //-->print the message

```

lcd.setCursor(0,1); // -->position cursor to row 0 position 1

lcd.print(" Duke matur! "); //-->print the message

//-----Configure the PulseSensor object, by assigning
our variables to it.

pulseSensor.analogInput(PulseWire);

pulseSensor.blinkOnPulse(LED_3); //--> blink Arduino's LED with heartbeat.

pulseSensor.setThreshold(Threshold);

//-----Double-check the "pulseSensor" object was
created and "began" seeing a signal.

if (pulseSensor.begin()) {

    //Serial.println("Krijuam pulseSensor Object !");

}

delay(2000);

lcd.clear();

}

//-----void loop

void loop() {

    int myBPM = pulseSensor.getBeatsPerMinute(); //--> Calls function on our
pulseSensor object that returns BPM as an "int". "myBPM" hold this BPM value now.

```

```
//-----Condition if the Sensor does not detect the heart  
rate / the sensor is not touched.
```

```
if (Instructions_view < 500) {
```

```
    Instructions_view++;
```

```
}
```

```
if (Instructions_view > 499) {
```

```
    lcd.setCursor(0,0); // -->position cursor to row 0 position 0
```

```
    lcd.print("Vendos Gishtin "); //-->print the message
```

```
    lcd.setCursor(0,1); // -->position cursor to row 0 position 1
```

```
    lcd.print("tek sensori "); //-->print the message
```

```
    delay(1000);
```

```
    lcd.clear(); //-->clean the lcd
```

```
    delay(500);
```

```
}
```

```
//Constantly test to see if "a beat happened".
```

```
if (pulseSensor.sawStartOfBeat()) { //--> If test is "true", then the following  
conditions will be executed.
```

```
    Serial.println("♥ Pulsi u kap ! "); //--> Print a message.
```

```
    Serial.print("BPM: "); //--> Print phrase "BPM: "
```

```
Serial.println(myBPM); //--> Print the value of myBPM.

//Displays a "Heart" shape on the LCD.

lcd.clear();

lcd.setCursor(1,1); //-->position cursor to row 1 position 1

lcd.write(byte(1));

lcd.setCursor(0,1); //-->position cursor to row 0 position 1

lcd.write(byte(2));

lcd.setCursor(0,0); //-->position cursor to row 0 position 0

lcd.write(byte(3));

lcd.setCursor(1,0); //-->position cursor to row 1 position 0

lcd.write(byte(4));

lcd.setCursor(2,0); // -->position cursor to row 2 position 0

lcd.write(byte(5));

lcd.setCursor(3,0); //-->position cursor to row 3 position 0

lcd.write(byte(6));

lcd.setCursor(3,1); //-->position cursor to row 3 position 0

lcd.write(byte(7));

lcd.setCursor(2,1); //-->position cursor to row 2 position 1

lcd.write(byte(8));

//-----
```



```

//-----Displays the BPM value on the LCD.

lcd.setCursor(5,0); //-->position cursor to row 5 position 0

lcd.print("Rrahjet");

lcd.setCursor(5,1); //-->position cursor to row 5 position 1

lcd.print(": "); //-->print the message

lcd.print(myBPM); //-->print value of BPM

lcd.print(" ");

lcd.print("BPM  "); //-->print the message

delay(2000);

Instructions_view = 0;

}

float h = dht.readHumidity(); //-->read the data for humidity,store on h variabel
lokale

// Read temperature as Celsius

float t = dht.readTemperature(); //-->read the data for temperature,store on t variabel
lokale

// Check if any reads failed and exit early (to try again).

if (isnan(h) || isnan(t)) {

Serial.println("Failed to read from DHT sensor!"); //-->print the message

```

```

    return;

}

//shfaq tekstin

Serial.print("Lageshtira: "); //-->print the message

Serial.print(h); //-->print the value of h

Serial.print(" %\t");

Serial.print("Temperatura: "); //-->print the message

Serial.print(t); //-->print the value of t

Serial.println(" *C ");

delay(3000);

lcd.clear();

lcd.clear(); //-->clean lcd

lcd.setCursor(0,0); //-->position cursor to row 0 position 0

lcd.print("Temp "); //-->print the message

lcd.print(t); //-->print the value of t

lcd.setCursor(0,1); //-->position cursor to row 0 position 1

lcd.print("Lageshtira "); //-->print the message

lcd.print(h); //-->print value of h

delay(3000);

if (gprsSerial.available())

```

```
Serial.write(gprsSerial.read());

gprsSerial.println("AT"); //-->command for the handshake protocol

delay(100);

gprsSerial.println("AT+CPIN?"); //-->check for the SIM card PIN

delay(100);

gprsSerial.println("AT+CREG?"); //-->register the network service

delay(100);

gprsSerial.println("AT+CGATT?"); //-->makes the connection of gprs service

delay(100);

gprsSerial.println("AT+CIPSHUT"); //-->close the connection process and open
TCP/UDP

delay(100);

gprsSerial.println("AT+CIPSTATUS"); //-->shows the status

delay(100);

gprsSerial.println("AT+CIPMUX=0"); //

delay(100);

ShowSerialData();

gprsSerial.println("AT+CSTT=\"vodafoneweb\""); //-->sets the APN for the SIM
card

delay(200);
```

```
ShowSerialData();

gprsSerial.println("AT+CIICR");//-->starts the connection

delay(100);

ShowSerialData();

gprsSerial.println("AT+CIFSR");//-->gets an IP

delay(1000);

ShowSerialData();

gprsSerial.println("AT+CIPSPRT=0");

delay(1000);

ShowSerialData();

gprsSerial.println("AT+CIPSTART=\"TCP\", \"api.thingspeak.com\", \"80\");//--
>makes the connection with thingspeak API

delay(1500);

ShowSerialData();

gprsSerial.println("AT+CIPSEND");//-->start to send the data

delay(1500);

ShowSerialData();
```

```

String                                                    str="GET
https://api.thingspeak.com/update?api_key=CM9F7J9F3GAUHL0J&field1="      +
String(myBPM) +"&field2="+String(t)+"&field3="+String(h); //-->api url and fields

Serial.println(str);

gprsSerial.println(str);

delay(1000);

ShowSerialData();

gprsSerial.println((char)26);//-->sending

delay(5000);//waitting for reply, important! the time is base on the condition of
internet

gprsSerial.println();

ShowSerialData();

gprsSerial.println("AT+CIPSHUT");//-->close the connection

delay(100);

ShowSerialData();

lcd.clear() ;

lcd.setCursor(3,0); //-->position cursor to row 3 position 0

  lcd.print("Transmetimi"); //-->print the message

lcd.setCursor(8,1); //-->position cursor to row 8 position 1

  lcd.print("OK "); //-->print the message

delay(2000);

```

//--> considered best practice in a simple sketch.

```
lcd.clear();
```

```
lcd.setCursor(0,0); //-->position cursor to row 0 position 0
```

```
  lcd.print("Frenk Topciu "); //-->print the message
```

```
lcd.setCursor(0,1); //-->position cursor to row 0 position 1
```

```
  lcd.print("EPOKA 2022 "); //-->print the message
```

```
  delay(2000);
```

```
}
```

```
void ShowSerialData()
```

```
{
```

```
  while(gprsSerial.available()!=0)
```

```
    Serial.write(gprsSerial.read());
```

```
    delay(3000);
```

```
}
```

In the figure below we have the circuit diagram of the project. I have used Arduino Mega as a microcontroller unit, an LCD as a display and all the sensors to measure the temperature and humidity.

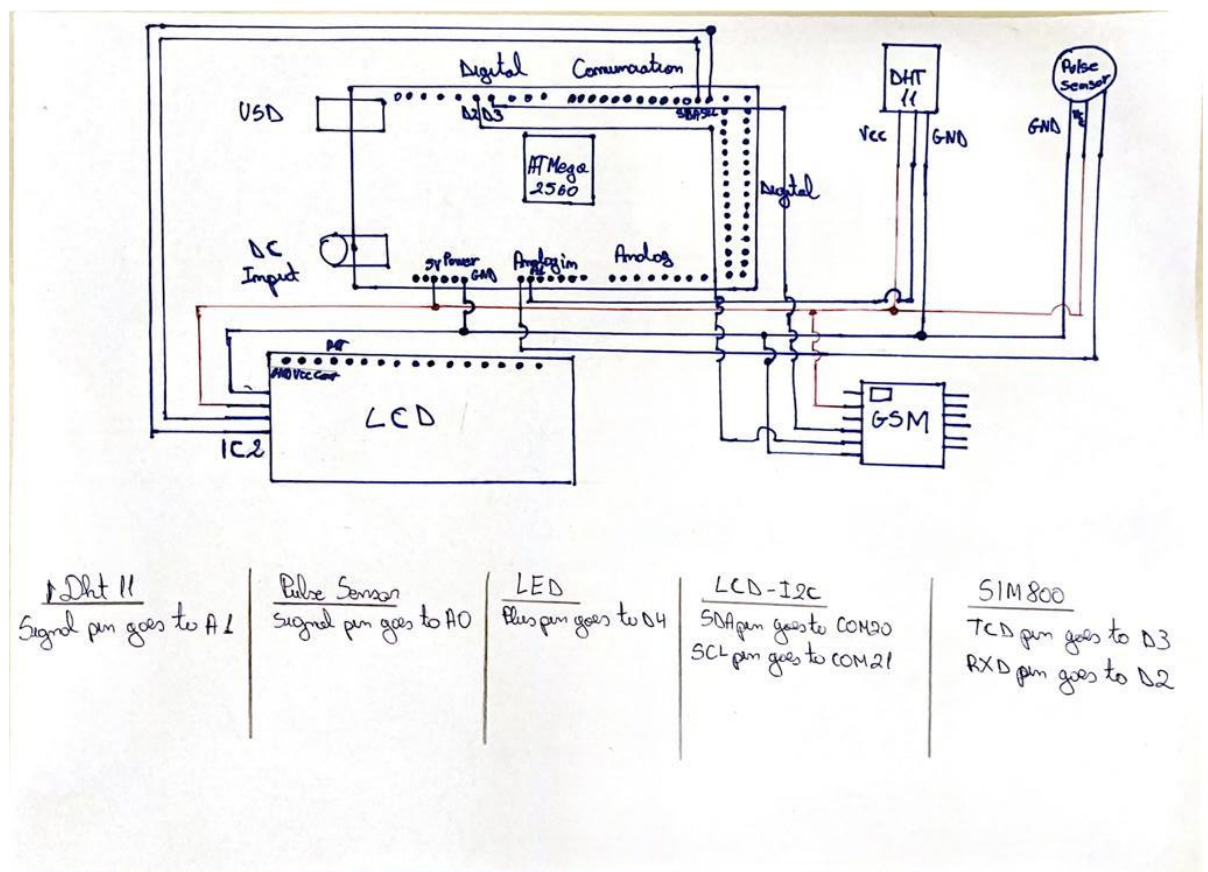
The DHT11 sensor is connected to A1.

The pulse sensor is connected to A0.

Led light is connected to D4.

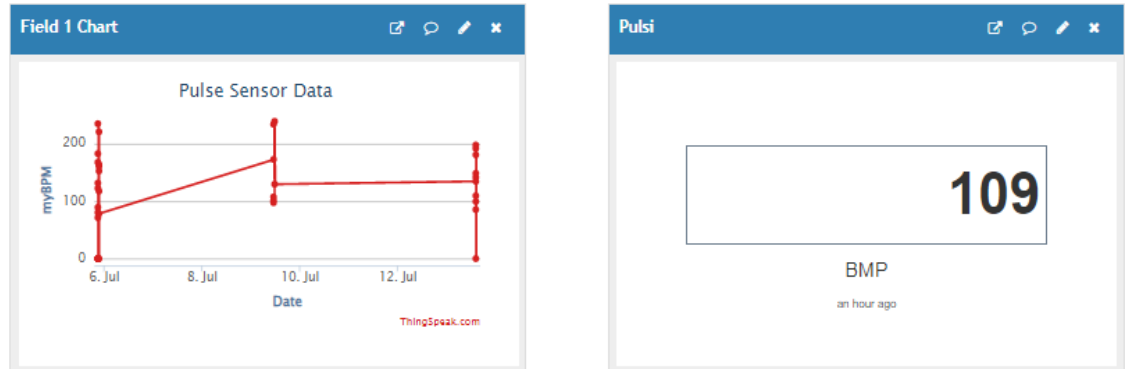
LCD I2C is connected to Com21 and Com20.

GSM Module is connected to D2 and D3.

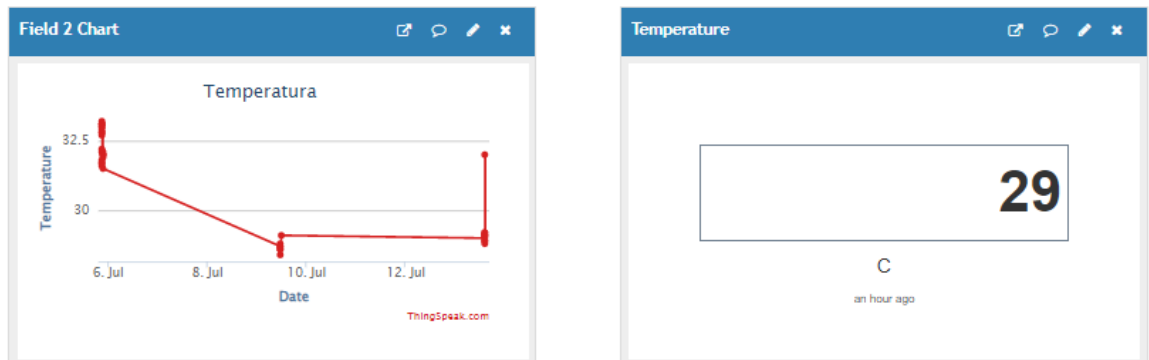


**Figure 17.** Circuit Diagram

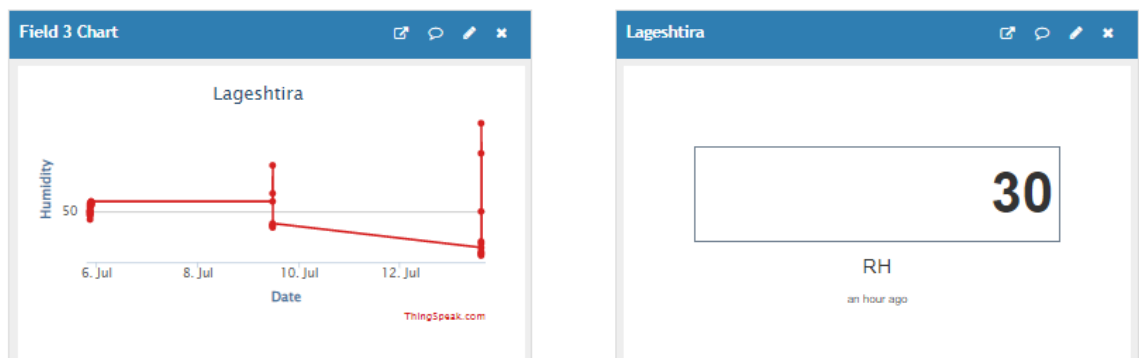
All the data that comes from sensors such as Humidity sensor, Temperature sensor and Pulse sensor are transmitted to Thingspeak using the GSM module. Thingspeak uses an API Key to upload data to the system and fields.



**Figure 18.** Heart Rate on Thingspeak



**Figure 19.** Temperature on Thingspeak



**Figure 20.** Humidity on Thingspeak



## RESULTS AND DISCUSSION

### DISCUSSION:

The Internet of Things-based remote healthcare monitoring systems are a system of medical devices that may gather and exchange information in order to spread various healthcare apps and services.

Healthcare practitioners are now accepting IoT-based wearable technologies, according to Dwivedi et al. [53], to fasten the diagnosis and recovery of one's health. However, there are several complexity and limitations to consider aspects that make ongoing improvement extremely difficult.

Therefore, some challenges and development issues:

- **Decision Support**

Ai and machine learning allow transdisciplinary creation and processing of analytical techniques such as monitoring and decision assistance, which are crucial for the future development of smart healthcare. Artificial intelligence & machine learning are now being widely researched as decision-making aids [54]. Many of the difficulties identified can be addressed with the help of such research. Latest machine learning and artificial intelligence technologies may not be able to completely replace doctors, but they can help to them communicate with crucial patients with information in a clear and understandable manner. Such technologies would not only help with decision-making, but they would also ensure the integrity and dependability of all the parts that make up the smart health - monitoring ecosystem.

- **Usability**

The goal of remote healthcare monitoring technology is to make diagnosis and treatment easier. Usability is always a crucial functionality concern when it comes to improving patient safety and health care delivery. User input is commonly used to analyze usability, and performance concerns are reported. Despite the fact that the Internet of Things (IoT) represents a complex cooperation among healthcare equipment, requirements must be changed in order to bring the network's parts together and improve the usability of remote healthcare monitoring systems. The Internet of Things will create a new generation of healthcare monitoring systems capable of anticipating and responding to shifting patient demands.

- **Accuracy and reliability**

The accuracy and dependability of healthcare data are dependent on remote healthcare monitoring technologies. Because false information may become unreliable and disruptive to patients, accuracy and reliability mechanisms must be ensured throughout time. IoT technology has a vested interest in incorporating and interpreting various types of clinical information into professional decision-making processes in remote healthcare monitoring systems, for example. Physicians will be able to analyze the condition of health for each patient in this manner, allowing for more effective therapies. This was accomplished using diagnostic exams, where progress correctness was critical to the patient's rescue.

- **Security and Privacy**

In smart healthcare, a highly secure health technology assessment procedure is critical. As remote healthcare monitoring systems become more frequently used, patient data confidentiality must be ensured.

Hackers can get access to personal data through security weaknesses, which can lead to crimes including fraud and identity theft, the exposure of unauthorized chemicals, and the production of fraudulent payroll records [55]. The reliability of infection prevention, vitality, and data collected from embedded sensing devices has become a critical issue for remote healthcare monitoring systems. Patients may suffer severe, and in some cases deadly, mass casualties as a result of security flaws in healthcare systems. One of the most important parts of assuring the structure of remote healthcare monitoring systems is network authentication. Due to a lack of processing capacity and resources, certain healthcare monitoring systems may not implement modern encryption techniques [33]. As a result, tackling security issues requires efficient and low-power computing combined with contemporary authentication systems.

- **Energy Efficiency**

In remote healthcare monitoring systems, smart sensors and devices that can function constantly onsite using perceived energy are widespread. The use of renewable energy for long-term healthcare monitoring appears to be a relatively recent concept. Researchers have been able to use the Internet of Things to test new technologies in order to lower the power consumption of different linked smart sensors and gadgets. As a result, numerous routing protocols, methods, and tactics have been shown to lower the overall amount of energy required to run the network. However, in order to limit the amount of power needed for processing and transmission, the volume of data generated must be regulated. Remote healthcare monitoring systems that are energy efficient can drastically reduce energy consumption in healthcare institutions and save money. These processes have a positive impact on the environment by reducing electromagnetic pollution.

## CONCLUSION

The Internet of Things-based patient monitoring system is an option that may be utilized to assist people with chronic conditions. Similarly, the goal of this group of remedies is to improve patients' quality of life.

In the future, the system might be modified and altered in a variety of ways.

When new sensors are added, the system's sensors may be upgraded, and we can monitor a variety of health metrics.

The system incorporates different ideas to produce a system that raises people's quality of life.

During the design and production of the individual modules, experience of electric circuit analysis was applied. Microcontrollers communicate with each other based on wireless technology and software programming is performed during microcontroller programming to create a final circuit system.

The complete system that I propose can be combined into a small device and make it easier for patients to take the device with them wherever they go.

In this case, VLSI technologies will be quite useful.

This study can be expanded in the future by adding blood pressure sensors to the existing setup. This work is based on health status and the data are taken by me, but it can be developed to include numerous persons in the future.

## REFERENCES

- 1-Sukanesh R., Gautham P. ;Arunmozhivarman P.T. ;Rajan S.P. ;Vijayprasath S. 'Cellular phonebased biomedical system for health care'Dept. of Electron. & Commun. Eng., Thiagarajar coll. of Eng.,Madurai, IndiaCommunication Control and Computing Technologies (ICCCCT), IEEE InternationalConference 2010.
- 2- Dr.R.Sukanesh, S.Palanivel rajan, S.Vijayprasath, S.Janardhana prabhu and P.Subathra 'gsm basedecg tele-alert system', Department of Electronics and Communication Engineering,2012/
3. Dept. of Electron. &Commun. Eng., Thiagarajar Coll. of Eng., Madurai, IndiaInnovative Computing Technologies (ICICT),International Conference 20103-Jones V, Gay V, Leijdekkers P. Body sensor networks for mobile health monitoring: experience in Europe and Australia. In: The fourth international conference on digital society, ICDS 2010, February 10–16, 2010, Netherlands Antilles; 2010.Google Scholar
- 4- Ljupčco Hadžievski, Boško Bojović, Vladan Vukčević, Petar Beliće, Siniša Pavlović,Zorana Vasiljević-Pokrajčić, and Miodrag Ostojic''A Novel Mobile Transtelephonic System WithSynthesized 12-Lead ECG'IEEE Transaction on Information Technology in Biomedicine, Volume 8,2018
- 5- Scherr D, Kastner P, Kollmann A, Hallas A, Auer J, Krappinger H, et al. MOBITEL investigators, effect of home-based telemonitoring using mobile phone technology on the outcome of heart failure patients after an episode of acute decompensation: randomized controlled trial. J Med Int Res 2009;11(3). [Google Scholar](#)
- 6- Yin, Y., Zeng, Y., Chen, X., Fan, Y.: The Internet of Things in healthcare: an overview. J.Ind. Inf. Integr. 1, 3–13 (2016)

- 7-** Mohammad Salah Uddin, Jannat B. Alam, Suraiya Banu. Published 1 September 2017. Computer Science 2017 4th International Conference on Advances in Electrical Engineering (ICAEE)
- 8-** Ramakrishna Hegde, S. Ranjana, C. Divya. Published 8 April 2021. Medicine, Computer Science 2021 5th International Conference on Computing Methodologies and Communication (ICCMC)
- 9-** Vivek Pardeshi, Saurabh Sagar, Swapnil Murmurwar, Pankaj Hage. "Health Monitoring Systems using IoT and Raspberry Pi – A Review", International Conference on Innovative Mechanism for Industry Applications, 2017
- 10-** Healthcare Data Challenge, available on line: <https://newsroom.ibm.com/>, Last accessed Jan. 2014
- 11-** L. C. Jersak, A. C. da Costa, D. A. Callegari, "A Systematic Review on Mobile Health Care", Tech. Report 073, Faculdade de Informática PUCRS – Brazil, May 2013.
- 12-** Shivam Gupta, Shivam Kashaudhan, Devesh Chandra Pandey, Prakhar Pratap Singh Gaur, International Research Journal of Engineering and Technology (IRJET) Volume: 04 Issue: 03 | Mar -2017 "IOT based. Patient Health Monitoring System"
- 13-** Minaie A. and Sanati-Mehrizy R. (2208). Comparison of Embedded Systems Education in the United States, European, and Far Eastern Countries. In the American Society for Engineering Education Annual Conference, pp. 13.19.1-13.19.6
- 14-** Ibrahim I., Ali R., Zulkefli M., and Elfadil N. (2015). Embedded Systems Pedagogical Issue: Teaching Approaches, Students Readiness, and Design Challenges. In the American Journal of Embedded Systems and Applications, pp. vol. 3, issue 1, pp. 1-10. <https://doi.org/10.11648/j.ajes.20150301.1> 2015.
- 15-** ARDUINO.CC, "Arduino – Introduction", 2015 [Online] Available: <http://arduino.cc/en/Guide/Introduction>. [Accessed: 25- Feb - 2015]
- 16-** Arduino.cc, 'Arduino - Products', 2015. [Online]. Available: <http://arduino.cc/en/Main/Products>. [Accessed: 25- Feb- 2015]
- 17-** ArduPilot Mega, 'ArduPilot Mega', 2015. [Online]. Available: <http://www.ardupilot.co.uk/>. [Accessed: 23- Nov- 2015].

- 18-** A. Alberdi, A. Aztiria, A. Basarab, Towards an automatic early stress recognition system for office environments based on multimodal measurements: a review, *J. Biomed. Inform.* 59 (2016) 49–75.
- 19-** R.G. Afkhami, G. Azarnia, M.A. Tinati, Cardiac arrhythmia classification using statistical and mixture modeling features of ECG signals, *Pattern Recogn. Lett.* 70 (2016) 45–51.
- 20-** ] S. Banerjee, M. Mitra, Application of Cross Wavelet Transform for ECG pattern analysis and classification, *IEEE Trans. Instrum. Meas.* 63 (2014) 326–333
- 21-** ] M. Merone, P. Soda, M. Sansone, C. Sansone, ECG databases for biometric systems: a systematic review, *Expert Syst. Appl.* 67 (2017) 189–202
- 22-** Blazer, DG. Social support and mortality in an elderly community population. *Am J Epidemiol* 1982; 115: 684–694. [Google Scholar](#) | [Crossref](#)
- 23-** Blazer, DG. Social support and mortality in an elderly community population. *Am J Epidemiol* 1982; 115: 684–694. [Google Scholar](#) | [Crossref](#)
- 24-** Weems A, Harding M and Choi A 2016 Classification of the ECG Signal Using Artificial Neural Network *Proceedings of the 3rd International Conference on Intelligent Technologies and Engineering Systems* 545-555 ICITES2014. [Google Scholar](#)
- 25-** Li, S., Xu, L. D., & Zhao, S. (2015). The internet of things: a survey. *Information Systems Frontiers*, 17(2), 243-259. <https://link.springer.com/article/10.1007/s10796-014-9492-7>
- 26-** Miao Wu, Tingjie Lu, +2 authors Hui-Ying Du. Published 20 September 2010. *Computer Science* 2010 3rd International Conference on Advanced Computer Theory and Engineering (ICACTE)3
- 27-** The Internet of Things – Promise for the Future? [https://www.researchgate.net/publication/232168440\\_The\\_Internet\\_of\\_Things\\_-\\_Promise\\_for\\_the\\_future\\_An\\_Introduction](https://www.researchgate.net/publication/232168440_The_Internet_of_Things_-_Promise_for_the_future_An_Introduction). April 25, 2022

- 28-** Vivek Singhania, "The Internet of Things: An Overview Understanding the Issues and Challenges of a More Connected World" (2015). ACADEMIA, online: ISOC-IoT-Overview-20151221-en.pdf(internetsociety.org
- 29-** K. Shafique, B. A. Khawaja, F. Sabir, S. Qazi and M. Mustaqim, "Internet of Things (IoT) for Next-Generation Smart Systems: A Review of Current Challenges, Future Trends and Prospects for Emerging 5G-IoT Scenarios," in IEEE Access, vol. 8, pp. 23022-23040, 2020, doi: 10.1109/ACCESS.2020.2970118.
- 30-** Minhaj Ahmad Khan, Khaled Salah, IoT security: Review, blockchain solutions, and open challenges, Future Generation Computer Systems, Volume 82, 2018.
- 31-** A. H. Ngu, M. Gutierrez, V. Metsis, S. Nepal and Q. Z. Sheng, "IoT Middleware: A Survey on Issues and Enabling Technologies," in IEEE Internet of Things Journal, vol. 4, no. 1, pp. 1-20, Feb. 2017, doi: 10.1109/JIOT.2016.2615180.
- 32-** Wheelus, C.; Zhu, X. IoT Network Security: Threats, Risks, and a Data-Driven Defense Framework. *IoT* **2020**, *1*, 259-285. <https://doi.org/10.3390/iot1020016>
- 33-** R. Mahmoud, T. Yousuf, F. Aloul and I. Zualkernan, "Internet of things (IoT) security: Current status, challenges and prospective measures," 2015 10th International Conference for Internet Technology and Secured Transactions (ICITST), 2015, pp. 336-341, doi: 10.1109/ICITST.2015.7412116.
- 34-** A. R. Biswas and R. Giaffreda, "IoT and cloud convergence: Opportunities and challenges," 2014 IEEE World Forum on Internet of Things (WF-IoT), 2014, pp. 375-376, doi: 10.1109/WF-IoT.2014.6803194.
- 35-** Roberta De Michele and Marco Furini. 2019. IoT Healthcare: Benefits, Issues and Challenges. In Proceedings of the 5th EAI International Conference on Smart Objects and Technologies for Social Good (GoodTechs '19). Association for Computing Machinery, New York, NY, USA, 160–164. <https://doi.org/10.1145/3342428.3342693>
- 36-** Farahani, B., Firouzi, F., Chakrabarty, K. (2020). Healthcare IoT. In: Firouzi, F., Chakrabarty, K., Nassif, S. (eds) Intelligent Internet of Things. Springer, Cham. [https://doi.org/10.1007/978-3-030-30367-9\\_11](https://doi.org/10.1007/978-3-030-30367-9_11)



**37-** R. K. Kodali, G. Swamy and B. Lakshmi, "An implementation of IoT for healthcare," 2015 IEEE Recent Advances in Intelligent Computational Systems (RAICS), 2015, pp. 411-416, doi: 10.1109/RAICS.2015.7488451.

**38-** S. Ge, S. Chun, H. Kim and J. Park, "Design and implementation of interoperable IoT healthcare system based on international standards," 2016 13th IEEE Annual Consumer Communications & Networking Conference (CCNC), 2016, pp. 119-124, doi: 10.1109/CCNC.2016.7444743.

**39-** [https://www.researchgate.net/profile/Sobhanbabu-Badugu-2/publication/348929916\\_IoT\\_for\\_Healthcare/links/6017b7d145851517ef2ead71/IoT-for-Healthcare.pdf](https://www.researchgate.net/profile/Sobhanbabu-Badugu-2/publication/348929916_IoT_for_Healthcare/links/6017b7d145851517ef2ead71/IoT-for-Healthcare.pdf), 2017.

**40-** Wu, T., Redouté, JM., Yuce, M. (2019). A Wearable, Low-Power, Real-Time ECG Monitor for Smart T-shirt and IoT Healthcare Applications. In: Fortino, G., Wang, Z. (eds) Advances in Body Area Networks I. Internet of Things. Springer, Cham. [https://doi.org/10.1007/978-3-030-02819-0\\_13](https://doi.org/10.1007/978-3-030-02819-0_13)

**41-** Shanmugasundaram.G, Sankarikaarguzhali.G,"An Investigation on IoT Healthcare Analytics", International Journal of Information Engineering and Electronic Business(IJIEEB), Vol.9, No.2, pp.11-19, 2017. DOI: 10.5815/ijieeb.2017.02.02

**42-** M. N. Bhuiyan, M. M. Rahman, M. M. Billah and D. Saha, "Internet of Things (IoT): A Review of Its Enabling Technologies in Healthcare Applications, Standards Protocols, Security, and Market Opportunities," in IEEE Internet of Things Journal, vol. 8, no. 13, pp. 10474-10498, 1 July1, 2021, doi: 10.1109/JIOT.2021.3062630.

- 43-** Y. A. Badamasi, "The working principle of an Arduino," 2014 11th International Conference on Electronics, Computer and Computation (ICECCO), 2014, pp. 1-4, doi: 10.1109/ICECCO.2014.6997578.
- 44-** A. A. Galadima, "Arduino as a learning tool," 2014 11th International Conference on Electronics, Computer and Computation (ICECCO), 2014, pp. 1-4, doi: 10.1109/ICECCO.2014.6997577.
- 45-** J. C. Martínez-Santos, O. Acevedo-Patino and S. H. Contreras-Ortiz, "Influence of Arduino on the Development of Advanced Microcontrollers Courses," in IEEE Revista Iberoamericana de Tecnologías del Aprendizaje, vol. 12, no. 4, pp. 208-217, Nov. 2017, doi: 10.1109/RITA.2017.2776444.
- 46-** Ismailov, A. S., & Jo‘rayev, Z. B. (2022). Study of arduino microcontroller board. *Science and Education*, 3(3), 172-179. Retrieved from <https://openscience.uz/index.php/sciedu/article/view/2740>
- 47-** D. Fisher and P. Gould, "Open-Source Hardware Is a Low-Cost Alternative for Scientific Instrumentation and Research," *Modern Instrumentation*, Vol. 1 No. 2, 2012, pp. 8-20. doi: [10.4236/mi.2012.12002](https://doi.org/10.4236/mi.2012.12002).
- 48-** W. Xi and L. Ling, "Research on IoT Privacy Security Risks," 2016 International Conference on Industrial Informatics - Computing Technology, Intelligent Technology, Industrial Information Integration (ICIICII), 2016, pp. 259-262, doi: 10.1109/ICIICII.2016.0069.
- 49-** <https://www.cs.purdue.edu/homes/bertino/paper-a.pdf0.pdf>

**50-** J. Daubert, A. Wiesmaier and P. Kikiras, "A view on privacy & trust in IoT," 2015 IEEE International Conference on Communication Workshop (ICCW), 2015, pp. 2665-2670, doi: 10.1109/ICCW.2015.7247581.

**51-** T. Gong, H. Huang, P. Li, K. Zhang and H. Jiang, "A Medical Healthcare System for Privacy Protection Based on IoT," 2015 Seventh International Symposium on Parallel Architectures, Algorithms and Programming (PAAP), 2015, pp. 217-222, doi: 10.1109/PAAP.2015.48.

**52-**H. Vincent Poor, Mario Goldenbaum, and Wei Yang. 2019. Fundamentals for IoT networks: secure and low-latency communications. In Proceedings of the 20th International Conference on Distributed Computing and Networking (ICDCN '19). Association for Computing Machinery, New York, NY, USA, 362–364.

<https://doi.org/10.1145/3288599.3288643>

**53-** A. D. Dwivedi, G. Srivastava, S. Dhar, and R. Singh, —A decentralized privacy-preserving healthcare blockchain for IoT,|| *Sensors (Switzerland)*, vol. 19, no. 2, pp. 1–17, 2019, doi: 10.3390/s19020326.

**54-** J. Qi, P. Yang, L. Newcombe, X. Peng, Y. Yang, and Z. Zhao, —An overview of data fusion techniques for Internet of Things enabled physical activity recognition and measure,|| *Inf. Fusion*, vol. 55, pp. 269–280, 2020, doi:

<https://doi.org/10.1016/j.inffus.2019.09.002>.

**55-**M. F. Ali, N. Harum, N. A. Abu, M. N. Al-Mhiqani, M. S. Talib, and A. A. Mohammed, —Protecting iot based transmitted data security using tokenized multiple layered encryption techniques,|| *Int. J. Adv. Sci. Technol.*, 2019



